

HALFEN HIT INSULATED CONNECTION STEEL TO CONCRETE CONNECTOR Technical Product Information

YOUR BEST CONNECTIONS





We are one team. **We are Leviat.**

Leviat is the new name of CRH's construction accessories companies worldwide.

Under the Leviat brand, we are uniting the expertise, skills and resources of HALFEN and its sister companies to create a world leader in fixing, connecting and anchoring technology.

The products you know and trust, including the HALFEN HIT Insulated connections, will remain an integral part of Leviat's comprehensive brand and product portfolio. As Leviat, we can offer you an extended range of specialist products and services, greater technical expertise, a larger and more agile supply chain and better, faster innovation.

By bringing together CRH's construction accessories family as one global organisation, we are better equipped to meet the needs of our customers, and the demands of construction projects, of any scale, anywhere in the world.

This is an exciting change. Join us on our journey.

Read more about Leviat at [Leviat.com](https://www.leviat.com)



Our product brands include:

Ancon[®]

HALFEN

PLAKA



60
locations

sales in
30+
countries

3000
people worldwide

Imagine. Model. Make.

Leviat.com

EXTREMELY ADAPTABLE

Did you know that squids adapt to their environment extremely well? They can pass through the smallest gaps, and thanks to their long tentacles, they can cling to anything, anywhere on the seabed. The HIT Steel to concrete insulated connection prefers to use its long rebars as reliable anchors in concrete. But the HIT is also very adaptable – especially when it involves tolerances in building!



Find out more at
[www.halfen.com!](http://www.halfen.com)

YOUR BEST CONNECTIONS

NEW: HIT INSULATED CONNECTIONS FOR STEEL TO CONCRETE CONNECTION

The new HALFEN HIT Steel to concrete connector is now available for connection of filigree steel components to concrete structures. This reduces thermal bridges while simultaneously ensuring high load transfer. The insulated connection elements are also freely height adjustable for easy compensation of construction tolerances.



CONTENTS

HALFEN HIT Insulated connection – Steel to concrete connection	4	
Overview of benefits	5	
Building materials/Test certificates	7	
Notes on calculation	8	
Verifying correct installation	11	
Using the installation aid	12	
1 HIT-HP SDV / HIT-SP SDV	14	
Load capacity range	15	
Load capacity values	16	
Product specifications	21	
On-site reinforcement	23	
Deformation	25	
Torsion spring stiffnesses	26	
Axial spacing, edge distance	27	
Installation instructions	29	
2 HIT-HP SMV / HIT-SP SMV	31	
Load capacity range	32	
Load capacity values	33	
Product specifications	35	
On-site reinforcement	36	
Deformation	37	
Torsion spring stiffnesses	38	
Axial spacing	39	
Installation instructions	41	
3 HIT-HP SZV / HIT-SP SZV	43	
Load capacity range	44	
Load capacity values	45	
Product specifications	46	
On-site reinforcement	47	
Axial spacing	48	
Installation instructions	50	
4 Construction and installation of connecting components	52	
On-site facing plate with notch	53	
Connecting supports	55	
Installation and height adjustment	56	
Installation, structural steel	57	
Expansion joint spacings	58	
5 Building physics	59	
Characteristic values for thermal bridges	60	
Characteristic thermal values according to Building Authority Approval	61	
Characteristic thermal values for HIT-HP Insulated connections	65	
Characteristic thermal values for HIT-SP Insulated connections	66	
Addresses / Technical support	68	

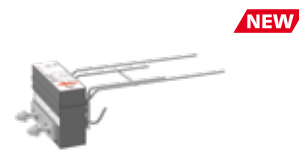
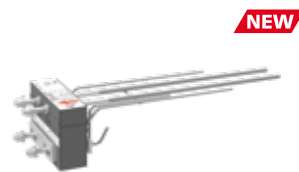
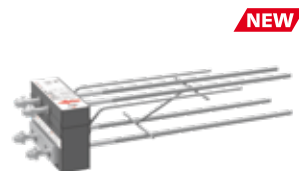

HALFEN HIT STEEL TO CONCRETE CONNECTOR

Introduction

HALFEN HIT Steel to concrete connector

Steel structures; steel balconies, steel canopies or solar shading systems are generally connected to reinforced concrete components. Because of the high thermal conductivity of steel, an efficient thermal separation in the connection is essential to prevent thermal bridges as these cause higher energy consumption, and to avoid structural damage caused by condensation and mould. HALFEN HIT Steel to concrete connectors reduce thermal bridges to a minimum with simultaneous high load transfer capabilities.

The core of the elements consists of a statically effective system of compression, tension and shear bars, which are anchored on-site in load-bearing concrete components. Tension and compression rods with metric connection threads are provided on the (exterior) balcony side. The system has an angled slotted bracket for freely height adjustment of connected components.

The load-bearing elements are tightly enclosed in a non-flammable mineral wool insulation; this significantly improves thermal separation. A robust housing encases and protects the insulation material from mechanical damage and the effects of weather. All load relevant elements in the connection and on the (exterior) balcony side are stainless steel to protect from corrosion and to ensure durability.

The following types of insulated connection are available:

- **HIT-SDV** as connection for freely cantilevered steel elements to transfer positive and negative bending moments and positive shear loads
- **HIT-SMV** as connection for freely cantilevered steel elements to transfer negative bending moments and positive shear loads
- **HIT-SZV** as connection for simply supported elements to reinforced concrete slabs to transfer positive shear loads
- all types are available with 80 mm (HIT-HP) and 120 mm (HIT-SP) thick insulation.

The HIT-SMV and HIT-SZV, with intelligent bar layout, are ideal for use with semi-precast filigree slabs, the short anchor heads do not come into contact with the reinforcement of the semi-precast slabs.

All types are delivered with an pre-fitted installation aid, these allow easy adjustment to facilitate installation in the formwork.

HIT-HP SMV-2M16

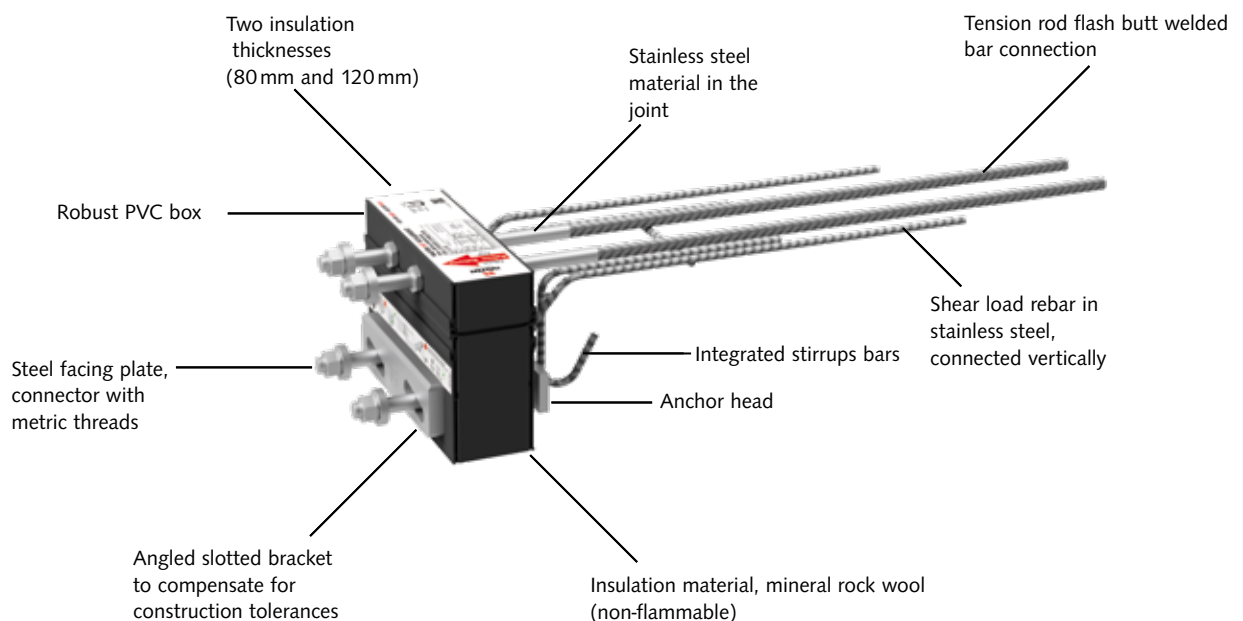

HALFEN HIT STEEL TO CONCRETE CONNECTOR Benefits in Planning and Installation

The benefits at a glance

► Reliable design and planning

- Building Authority Approval including determination of the equivalent thermal conductivity (λ_{eq})
- type tested
- chi-values for masonry with *ETICS available, other values on request

*ETICS External Thermal Insulation Composite System.

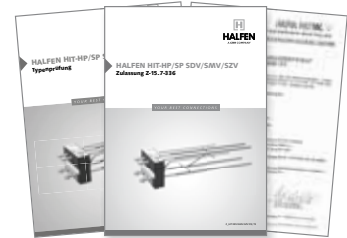

► Robust box

- reliable and sturdy box for installation in construction site conditions
- weather-resistance, reliable protection of the insulation material
- robust box ensures reliable connection of attached steel components

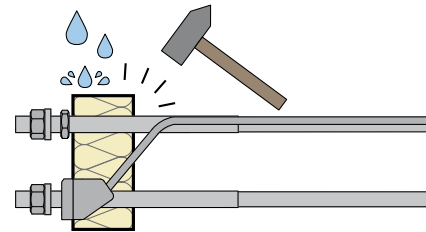

► Pre-fitted installation aid

- installation aid is pre-fitted as standard
- facilitates installation and adjustment in the formwork
- everything required is included in delivery; no additional costs

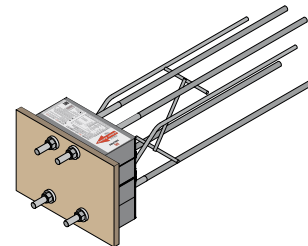

► Vertical adjustment of the steel with an angled slotted bracket

- pre-fitted steel bracket with angled slots, lateral movement provides vertical adjustment
- freely adjustable
- robust design, suitable for building site conditions

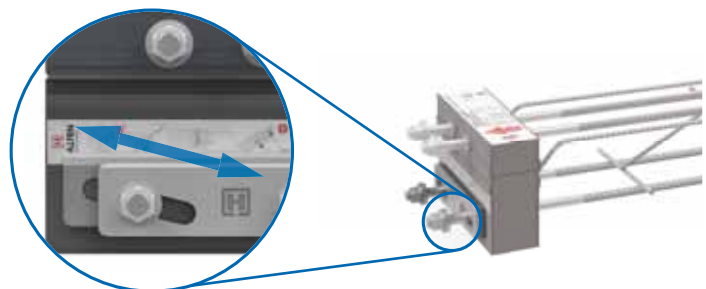

► Reliable notched support

- angled slotted bracket with bevelled edge, ensures support surface for the connecting notched is flat.
- no unintentional movement or twisting
- reliable, force-locked transfer of loads

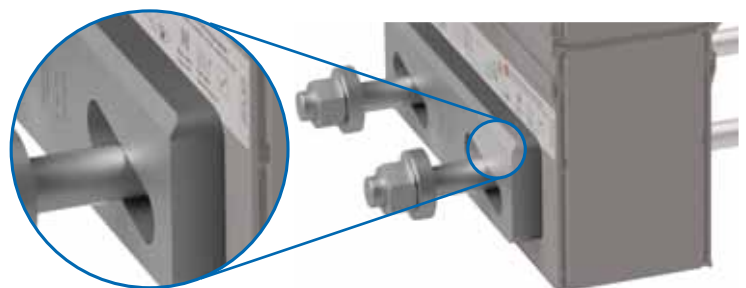

HALFEN HIT STEEL TO CONCRETE CONNECTOR

Product Overview – Thermally Insulated Connections

1

SDV

1 Cantilevered balcony slabs

HIT-HP SDV / HIT-SP SDV

Transfer of bi-directional bending moments and positive shear loads
 • insulation thickness 80 mm / 120 mm
 → page 13

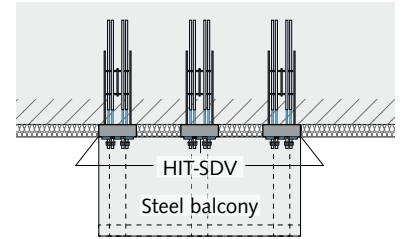
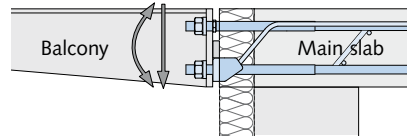

2

SMV

2 Cantilevered balcony slabs

HIT-HP SMV / HIT-SP SMV

Transfer of negative bending moments and positive shear loads
 • insulation thickness 80 mm / 120 mm
 → page 31

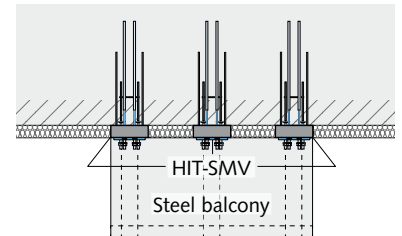
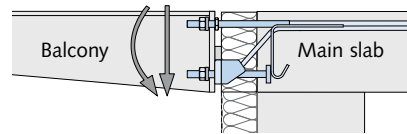

3

SZV

3 Simply supported balcony slabs on columns

HIT-HP SZV / HIT-SP SZV

Only for shear load transfer in positive direction
 • insulation thickness 80 mm / 120 mm
 → page 43

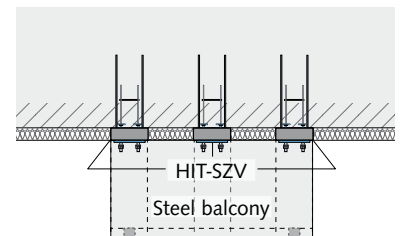
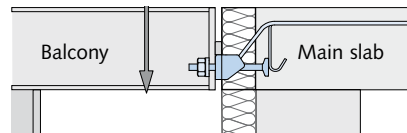

4

CONSTRUCTION

4 Construction

HIT-HP/SP SDV, SMV, SZV

• Design and installation of connected components
 → page 52

5

BUILDING PHYSICS

5 Building physics

HIT-HP/SP SDV, SMV, SZV

• Building physics, characteristic values
 → Page 59

HALFEN HIT STEEL TO CONCRETE CONNECTOR

Material Specification and Test Certificates

Materials; HIT Elements	
Tension/compression rods	Flash butt welded bar connection, consisting of a combination of two reinforcing steel bars B500 according to DIN 488, and stainless steel bars of strength class S690 or stainless steel B500NR with partial or full metric threads, for connection of steel components to the (exterior) side of the HIT element.
Load-bearing support	Stainless steel bars, strength class S 690 with partial or full metric threads on the steel connection side of the element, and anchor heads on the concrete side.
Shear load rebar	Stainless steel bars in strength class B500NR or flash butt welded bar connection, consisting of a combination of stainless steel bar B500NR and reinforcing steel bars B500
Installation bracket	Stainless steel, strength class S460
Angled slotted bracket	Stainless steel, strength class S235
Accessories	Stainless steel washers in strength class S460, Stainless steel bolt-nuts in strength class A4-80
Box	PVC plastic according to EN ISO 1163
Insulation material	Mineral wool (WLG 035) Building Material Class A1 – non-flammable insulation according to DIN 4102-14 or Euroclass A1 in accordance with EN 13501-1

Materials; load bearing concrete components	
Concrete	Suitable for concrete strength \geq C20/25
On-site reinforcement	B500 Reinforcement steel

Materials; connected steel components	
Steel	Steel according to EN 1993 or stainless steel according to approval Z-30.3-6 Required minimum strength class of steel on the balcony side: S 235

Test certificates

Building Authority Approvals	
HIT-HP/SP SDV	DIBT* Berlin: Approval no. Z-15.7-336
HIT-HP/SP SMV	
HIT-HP/SP SZV	*(German Institute of Building Technology)

Type tests	
Type tested by the LGA Landesgewerbeanstalt Bayern	Test no. S-WUE/100358 (German certification institute)



Approvals and type tests on the internet

The approvals and type tests can be found at www.halfen.com/downloads/brochures.
Or simply scan the code and then select the document to download the PDF file.



HALFEN HIT STEEL TO CONCRETE CONNECTOR Calculation

Notes on calculation

The connection is used as a thermally insulated, load-bearing connection of steel components to load-bearing reinforced concrete components.

The load-bearing structure requires a reinforced concrete element according to EN 1992-1-1 (minimum concrete strength C20/25; density $2,000 \text{ kg/m}^3 - 2,600 \text{ kg/m}^3$). Connected steel component must be in accordance with EN 1993 (e.g. balconies, canopies). The element is used for predominantly static loads.

The load-bearing concrete and the connected steel components must be verified by a structural engineer in accordance with current applicable standards. Design and static verification according to EN 1992-1-1 for the load-bearing component, and according to EN 1993 for the connected component. For verification, the loads on the connected structure must be calculated in accordance with EN 1991.

HALFEN HIT-HP HALFEN HIT-SP	SDV 2M16 SMV 2M16 SZV 2M16	SDV 2M22
HIT Height h [mm]	Inner cantilever z_i [mm]	Inner cantilever z_i [mm]
180	113	108
200	133	128
220	153	148
240	173	168
260	193	188
280	213	208



Corrosion protection

The stainless steels used comply with corrosion resistance class III/medium. Using the HALFEN HIT Steel to Concrete connectors in combination with galvanized or facing plates treated with corrosion protection coatings (i.e. paint) is non critical when considering galvanic corrosion, as the area of the facing plate is considerably larger than the surface area of

For indirect support of the HIT element, the transfer of loads from the connected element to the load-bearing component must be verified separately by the structural engineer. The insulation element is not designed for transfer of torsion loads; therefore, torsion-free installation must be ensured. Any torsion interaction between adjacent insulation elements must be prevented.

The load capacities are provided for the standard element height. Slabs thicknesses greater than the specified standard concrete coverings are possible, the element load capacities must always be selected for the possible internal cantilever z_i .

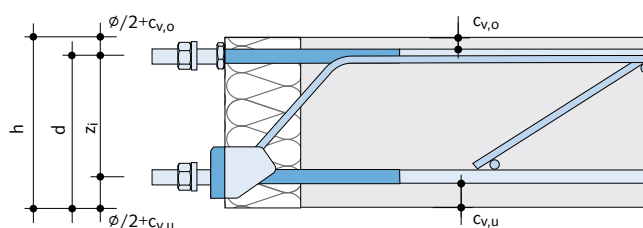

Inner cantilever and component height

the stainless steel. Consequently, a failure of the connection caused by contact corrosion is prevented.

Shortening the threaded connections

The threaded connection rods may be shortened as required; at least two thread must remain visible after final installation of steel components.

HALFEN HIT STEEL TO CONCRETE CONNECTOR

Calculation

Connection details HIT-SDV / HIT-SMV

The elements are delivered with a standard width of $b = 250\text{ mm}$.
Smaller widths, from $220 \leq b \leq 250\text{ mm}$ are available as custom lengths on request.

The structural engineer has to verify that the design values of the loads in the selected section do not exceed the specified resistance.

The horizontal and vertical axial spacings of the tension and compression elements are decisive for the design of the connected component. The axial spacing of the tension bars is 70 mm for all elements, for the compression rods 115 mm . The vertical spacing results from the selected element height h :

$$M16: z_i = h - 67$$

$$M22: z_i = h - 72$$

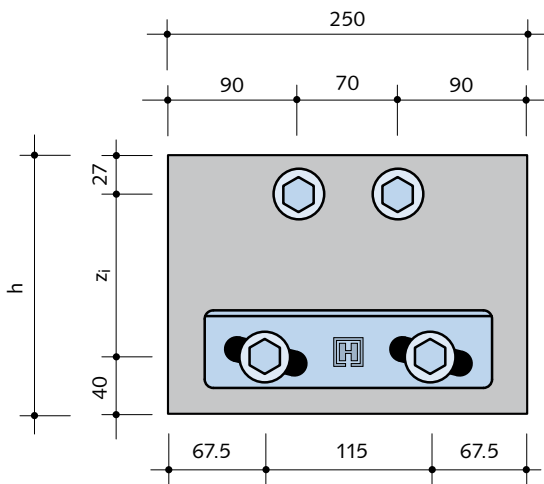

Spacings with HIT-SDV and HIT-SMV with M16 thread

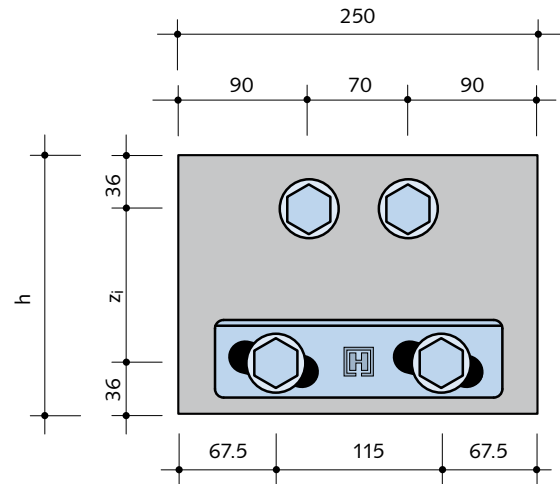

Spacings with HIT-SDV with M22 thread

Dimensions in [mm]

For HIT-SDV and HIT-SMV elements, the design values for resistance at ultimate load capacity are shown for two sections: The verification can be performed either in section A-A or section B-B. The two sections are mathematically linked, i.e. if the check is performed in one of the two sections (usually B-B), it is automatically fulfilled in the other section.

Section A-A Design section according to Z-15.7-336 (section in axis of tension and shear load bars)

Section B-B Design section at connection surface of steel component (surface of the facing plate to the connected component)

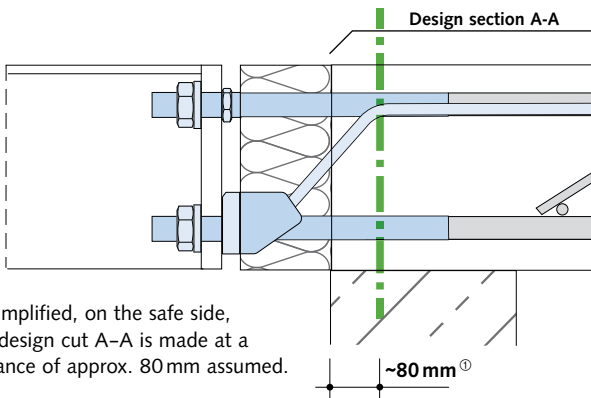

① Simplified, on the safe side, the design cut A-A is made at a distance of approx. 80 mm assumed.

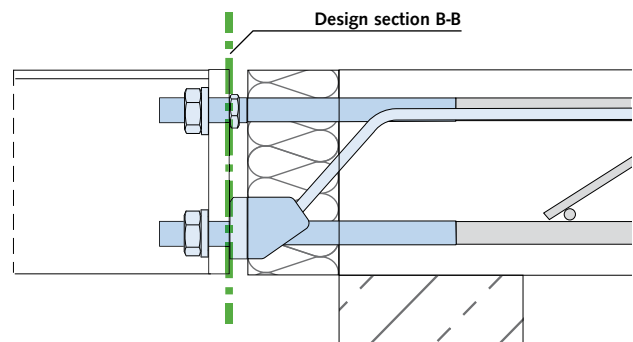

HALFEN HIT STEEL TO CONCRETE CONNECTOR Calculation

With HIT-SDV and HIT-SMV elements there is a dependency between the moment load capacity and the shear load in section B-B.

Therefore the tables show four value pairs V_{Rd}/M_{Rd} .

- Intermediate values may be linearly interpolated.
- Extrapolation for larger shear load values ($V_{Ed} > V_{Rd,4}$) is not possible.

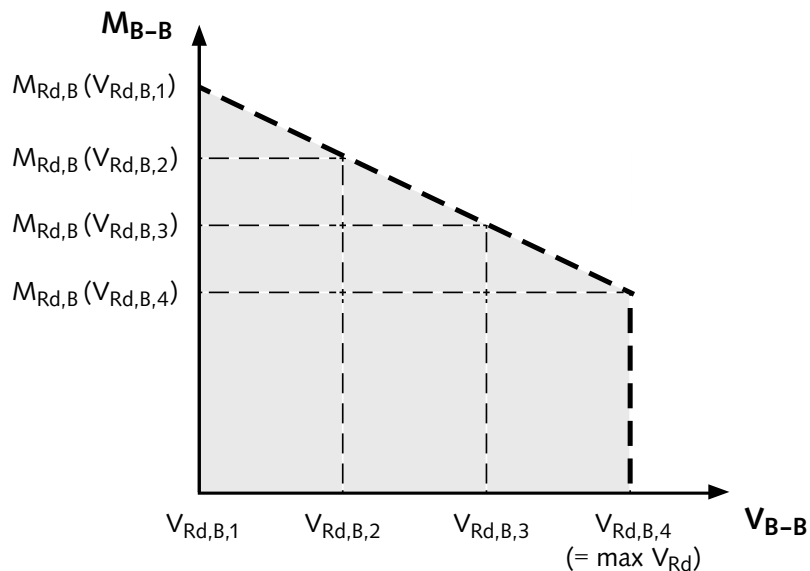

Figure: Dependency of moments and shear forces in section B-B

HIT-SZV Connection details

The HIT-SZV element is delivered with a standard width of $b = 250$ mm. Smaller widths, $220 \leq b \leq 250$ mm, are possible on request. Decisive for the design of the connected component are the axial spacings (horizontal and vertical) of the compression elements – the axial spacings of the compression bars is 115 mm for all elements.

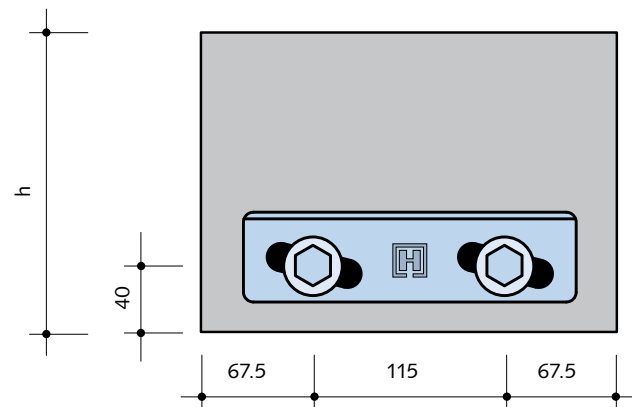
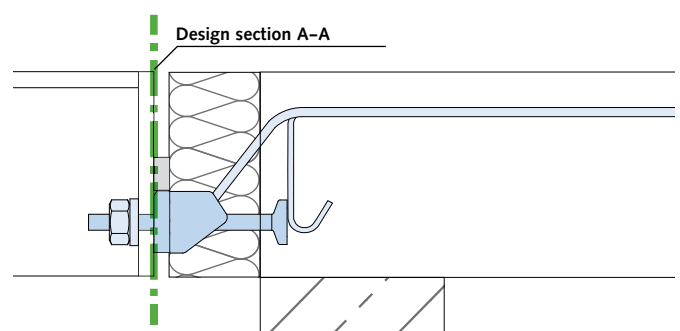

Figure: Spacings for HIT-SZV with M16 thread

The provided design values for load carrying capacity apply for the rear-most surface of the facing plate of the connected element. See section A-A.



HALFEN HIT STEEL TO CONCRETE CONNECTOR

Verifying correct installation

Verifying correct installation

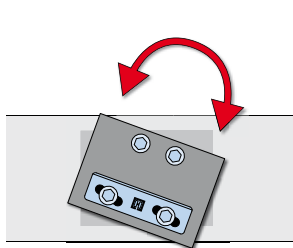

✗ incorrect rotated horizontal orientation

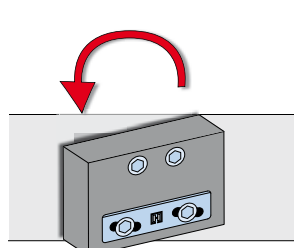

✗ incorrect twisted horizontal orientation

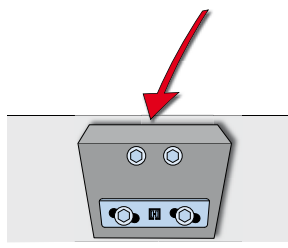

✗ incorrect tilted vertically!

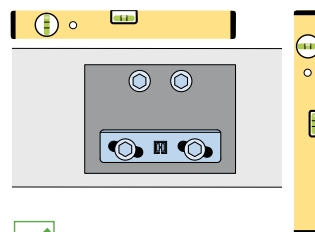

✓ correct!

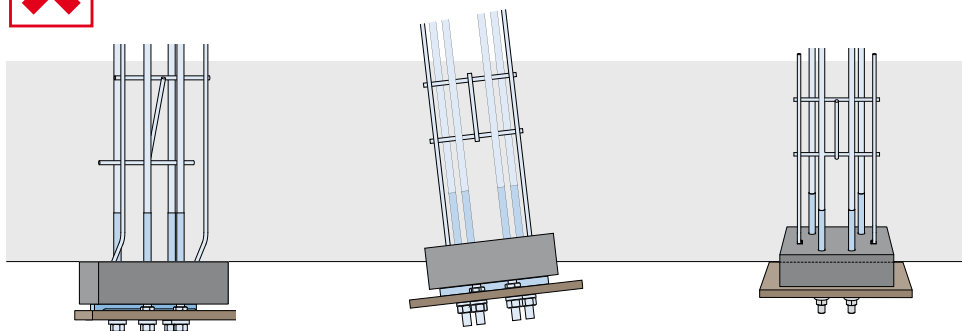

✗ incorrect: elements askew, horizontal to the concrete edge, towards the front or back

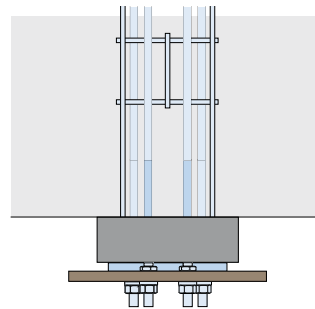

✓ correct: element aligned along axis

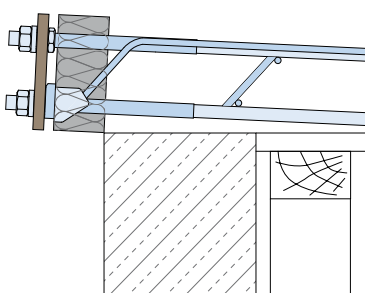

✗ incorrect tilted vertically

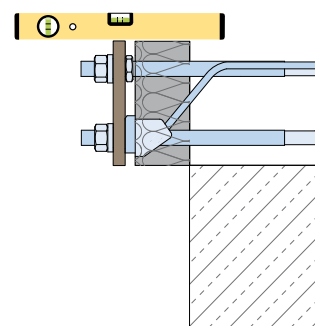
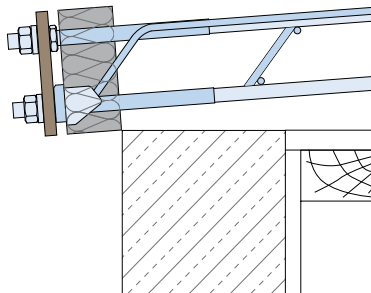

✓ correct: vertically aligned

HALFEN HIT STEEL TO CONCRETE CONNECTOR Installation aid

Using the installation aid

Transport protection doubles as installation aid

Each HIT element connection steel to concrete is delivered with a fitted transport protection, which is also used as an installation aid.

Primarily, the transport protection board shields the insulation box and connection bolts from damage; the connection bolts' orientation is also protected. The orientation of the bolts is critical and therefore requires special protection during concreting.

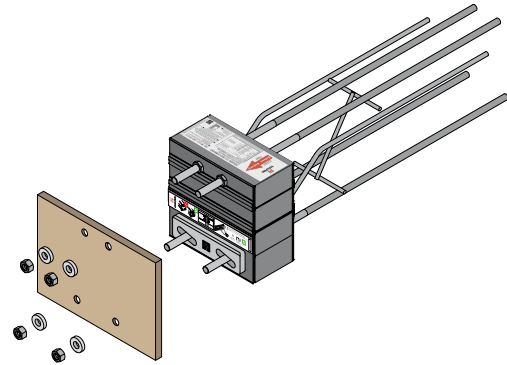
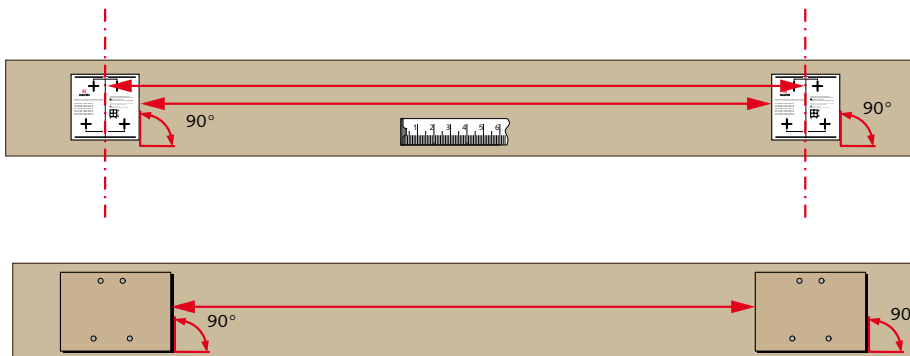

Figure: HIT-HP SDV and installation aid

The protection boards should remain in position during concreting or matching holes must be provided in the on-site formwork. If the installation aids are not removed from the elements, they can be used for alignment and connection to the on-site formwork. It must be ensured on-site that the installation aids are aligned vertically.

The excess ends of the installation aids can be used as required to fix the element to the formwork. If the elements are to be inserted directly through the formwork or using the installation aids, these can be removed and used as templates to set the drill holes and element spacings.



Figures: above: Installation aid on formwork using drill templates, below: Installation aid on formwork – aligned

Vertical orientation of the installation aid

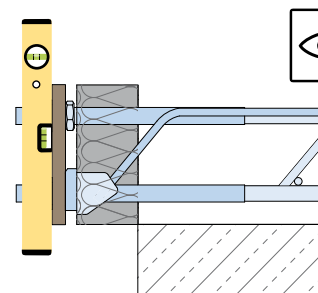
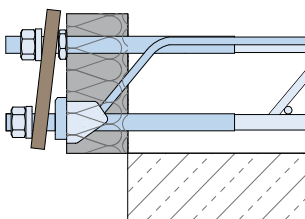

✗ incorrect Installation aid tilted vertically

✓ correct: Installation aid vertically aligned

Notes on the installation aids

Drill templates are available for download.

Alternatively, Drill templates are available as PDF files for free download. The templates can be printed and attached to the formwork for measuring and drilling.

When printing the files, ensure the correct scale is set: Page setting should be "actual size" or 100%. The control grid (2x2 cm) should also be checked for correct size after printing the template.

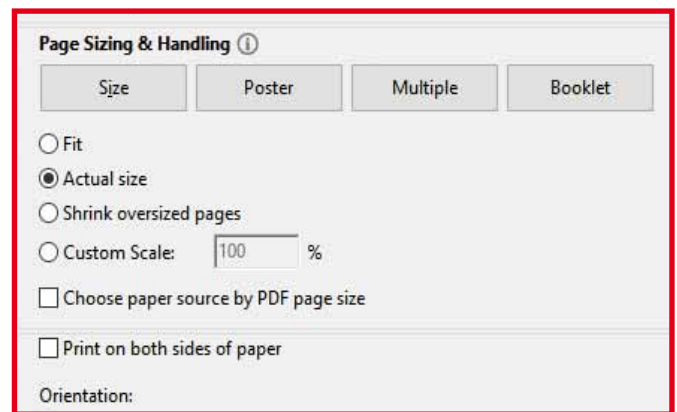
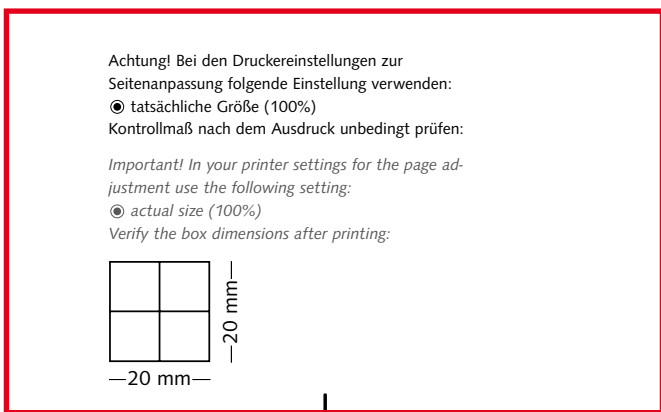
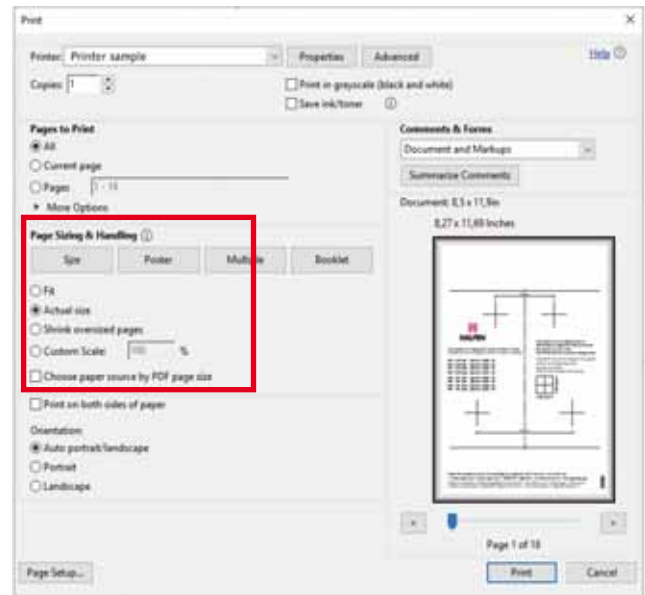
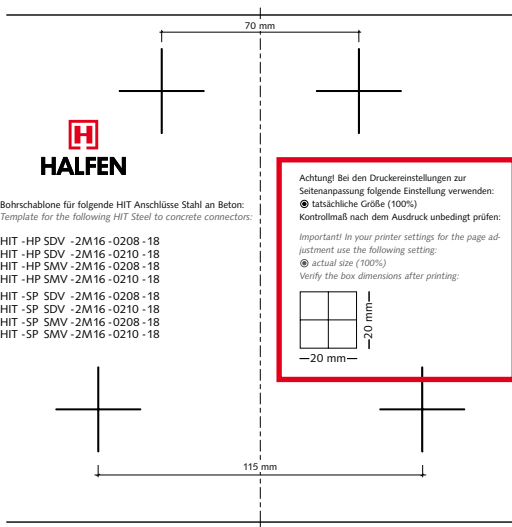

i A free drilling template (.pdf file) is available at:
 ▶ www.halfen.com ▶ Product Ranges ▶ Construction
 ▶ Reinforcement systems ▶ HIT Steel to Concrete Connector
 ▶ Product Information ▶ Installation Instructions

! Please note: Ensure the *Actual size* option is active in the *Print* menu when printing the drilling templates. Check the printed templates for correct dimensions!

HALFEN HIT STEEL TO CONCRETE CONNECTOR HIT-HP SDV, HIT-SP SDV

1

- > Connection system for attaching steel elements to reinforced concrete structures
- > Transfer of bi-directional bending moments and positive shear loads

TYPE TESTED

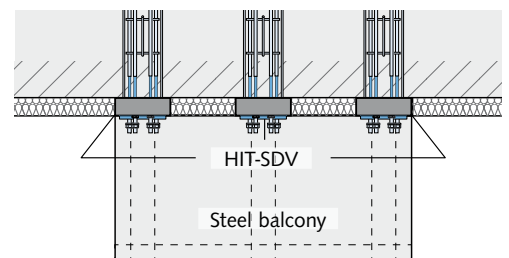
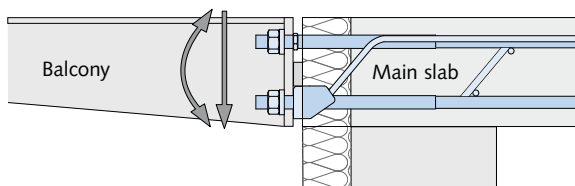

Application: Cantilevered balcony

HIT-HP SDV - High Performance with 80 mm insulation
HIT-SP SDV - Superior Performance with 120 mm insulation

Contents	Type	Page
Load range	HIT-HP SDV, HIT-SP SDV	15
Load capacity values	HIT-HP SDV, HIT-SP SDV	16
Product description	HIT-HP SDV, HIT-SP SDV	21
On-site connecting reinforcement	HIT-HP SDV, HIT-SP SDV	23
Deformation	HIT-HP SDV, HIT-SP SDV	25
Torsion spring stiffnesses	HIT-HP SDV, HIT-SP SDV	26
Axial spacings	HIT-HP SDV, HIT-SP SDV	27
Installation instructions	HIT-HP SDV, HIT-SP SDV	29

HALFEN HIT STEEL TO CONCRETE CONNECTOR

HIT-HP SDV, HIT-SP SDV

Load capacity ranges

Combinations of two moment and three shear load capacities are available. The following combinations of tension and shear bars are available for HIT-HP (80 mm thick insulation) and HIT-SP (120 mm thick insulation).

Element width B = 25 cm				
Number and diameter of balcony side connection threads	Number and diameter of tension and compression bars on slab side	Number and diameter of the shear load bars		
		2 ϕ 8	2 ϕ 10	2 ϕ 12
2M16	2 ϕ 14	•	•	
2M22	2 ϕ 20	•	•	•

Design values for selected elements can be found on the following pages • = HP and SP

Basic types - Ordering example

Ordering example

HIT-HP	SDV	-	2M16	-	0208	-	18
HIT-SP	SDV	-	2M22	-	0212	-	28
①	②	③	④	⑤	⑥		



CUSTOM SOLUTIONS

HALFEN HIT Insulated connections

Our technical support team is available if a custom solution is required for your project.

Contact details: → see back cover of catalogue

Type designation

- ① Product group
- ② Joint spacing 80 mm (HP) or 120 mm (SP)
- ③ Connection type
- ④ Moment load range
- ⑤ Shear load range
- ⑥ Element height [cm]

Technical specifications

Element designation HIT-HP/HIT-SP	Possible element heights h [cm]	Balcony connection Thread	Main slab			min. concrete cover, slab [mm]	
			Tension rod [mm]	Compression rod [mm]	Shear load rod [mm]	C _{v,top}	C _{v,bottom}
SDV-2M16-0208	18-28	2 M16	2 ϕ 14	2 ϕ 14	2 ϕ 8	20	33
SDV-2M16-0210		2 M16	2 ϕ 14	2 ϕ 14	2 ϕ 10	20	33
SDV-2M22-0208		2 M22	2 ϕ 20	2 ϕ 20	2 ϕ 8	26	26
SDV-2M22-0210		2 M22	2 ϕ 20	2 ϕ 20	2 ϕ 10	26	26
SDV-2M22-0212		2 M22	2 ϕ 20	2 ϕ 20	2 ϕ 12	26	26

HALFEN HIT STEEL TO CONCRETE CONNECTOR HIT-HP SDV

Resistance at ultimate load capacity



Shear capacity / Moment bearing capacity

Concrete strength: C20/25 ≥ C25/30



HIT-HP SDV 2M16-0208	Section A-A V _{Rd,A} [kN]		Section B-B for selected shear load V _{Rd,B} [kN]							
	33.5	33.5	10.0	10.0	20.0	20.0	30.0	30.0	33.5	33.5
Design values	33.5	33.5	10.0	10.0	20.0	20.0	30.0	30.0	33.5	33.5
Element height [mm]	M _{Rd,A} [kNm]		M _{Rd,B} [kNm]							
180	-13.9 12.5	-15.1 14.7	-12.5 12.5	-13.7 14.7	-11.1 12.5	-12.3 14.7	-9.7 12.5	-10.9 14.7	-9.2 12.5	-10.5 14.7
200	-16.0 14.6	-17.8 17.1	-14.4 14.6	-16.2 17.1	-12.8 14.6	-14.7 17.1	-11.3 14.6	-13.1 17.1	-10.7 14.6	-12.6 17.1
220	-18.1 16.7	-20.5 19.5	-16.3 16.7	-18.8 19.5	-14.6 16.7	-17.0 19.5	-12.9 16.7	-15.3 19.5	-12.3 16.7	-14.7 19.5
240	-20.2 18.8	-23.2 22.0	-18.3 18.8	-21.3 22.0	-16.4 18.8	-19.4 22.0	-14.5 18.8	-17.5 22.0	-13.8 18.8	-16.8 22.0
260	-22.3 20.9	-25.8 24.4	-20.2 20.9	-23.8 24.4	-18.1 20.9	-21.7 24.4	-16.1 20.9	-19.6 24.4	-15.3 20.9	-18.9 24.4
280	-24.4 23.0	-28.4 26.9	-22.1 23.0	-26.2 26.9	-19.9 23.0	-24.0 26.9	-17.7 23.0	-21.7 26.9	-16.9 23.0	-21.0 26.9

Load bearing capacity values for further types and for concrete strength C30/37 can be found in the type tests at www.halfen.com or on request. See back cover for contact information.

HIT-HP SDV 2M16-0210	Section A-A V _{Rd,A} [kN]		Section B-B for selected shear load V _{Rd,B} [kN]							
	52.3	52.3	30.0	30.0	40.0	40.0	50.0	50.0	52.3	52.3
Design values	52.3	52.3	30.0	30.0	40.0	40.0	50.0	50.0	52.3	52.3
Element height [mm]	M _{Rd,A} [kNm]		M _{Rd,B} [kNm]							
180	-13.9 12.5	-15.1 14.7	-9.7 12.5	-10.9 14.7	-8.3 12.5	-9.6 14.7	-6.9 12.5	-8.2 14.7	-6.6 12.5	-7.8 14.7
200	-16.0 14.6	-17.8 17.1	-11.3 14.6	-13.1 17.1	-9.7 14.6	-11.6 17.1	-8.1 14.6	-10.0 17.1	-7.8 14.6	-9.6 17.1
220	-18.1 16.7	-20.5 19.5	-12.9 16.7	-15.3 19.5	-11.1 16.7	-13.6 19.5	-9.4 16.7	-11.8 19.5	-9.0 16.7	-11.4 19.5
240	-20.2 18.8	-23.2 22.0	-14.5 18.8	-17.5 22.0	-12.6 18.8	-15.6 22.0	-10.7 18.8	-13.7 22.0	-10.2 18.8	-13.2 22.0
260	-22.3 20.9	-25.8 24.4	-16.1 20.9	-19.6 24.4	-14.0 20.9	-17.6 24.4	-11.9 20.9	-15.5 24.4	-11.5 20.9	-15.0 24.4
280	-24.4 23.0	-28.4 26.9	-17.7 23.0	-21.7 26.9	-15.4 23.0	-19.5 26.9	-13.2 23.0	-17.3 26.9	-12.7 23.0	-16.8 26.9

Load bearing capacity values for further types and for concrete strength C30/37 can be found in the type tests at www.halfen.com or on request. See back cover for contact information.



The verification can be performed either in section A-A or in section B-B.

HALFEN HIT STEEL TO CONCRETE CONNECTOR HIT-HP SDV

Resistance at ultimate load capacity



Shear capacity / Moment bearing capacity

Concrete strength: C20/25 ≥ C25/30



HIT-HP SDV 2M22-0208	Section A-A $V_{Rd,A}$ [kN]		Section B-B for selected shear load $V_{Rd,B}$ [kN]							
	33.5	33.5	10.0	10.0	20.0	20.0	30.0	30.0	33.5	33.5
Design values	33.5	33.5	10.0	10.0	20.0	20.0	30.0	30.0	33.5	33.5
Element height [mm]	$M_{Rd,A}$ [kNm]		$M_{Rd,B}$ [kNm]							
180	-27.4 16.1	-29.5 18.8	-26.0 16.1	-28.1 18.8	-24.7 16.1	-26.8 18.8	-23.3 16.1	-25.4 18.8	-22.9 16.1	-24.9 18.8
200	-32.5 18.7	-35.0 22.0	-31.0 18.7	-33.4 22.0	-29.4 18.7	-31.9 22.0	-27.9 18.7	-30.4 22.0	-27.4 18.7	-29.9 22.0
220	-37.1 21.5	-40.4 25.2	-35.4 21.5	-38.7 25.2	-33.7 21.5	-37.0 25.2	-32.0 21.5	-35.3 25.2	-31.4 21.5	-34.8 25.2
240	-41.4 24.2	-45.7 28.4	-39.5 24.2	-43.9 28.4	-37.7 24.2	-42.0 28.4	-35.8 24.2	-40.1 28.4	-35.2 24.2	-39.5 28.4
260	-45.6 26.9	-50.3 31.6	-43.6 26.9	-48.2 31.6	-41.5 26.9	-46.2 31.6	-39.5 26.9	-44.2 31.6	-38.8 26.9	-43.5 31.6
280	-49.7 29.7	-54.7 34.8	-47.5 29.7	-52.5 34.8	-45.4 29.7	-50.4 34.8	-43.2 29.7	-48.2 34.8	-42.5 29.7	-47.5 34.8

Load bearing capacity values for further types and for concrete strength C30/37 can be found in the type tests at www.halfen.com or on request. See back cover for contact information.

HIT-HP SDV 2M22-0210	Section A-A $V_{Rd,A}$ [kN]		Section B-B for selected shear load $V_{Rd,B}$ [kN]							
	52.3	52.3	30.0	30.0	40.0	40.0	50.0	50.0	52.3	52.3
Design values	52.3	52.3	30.0	30.0	40.0	40.0	50.0	50.0	52.3	52.3
Element height [mm]	$M_{Rd,A}$ [kNm]		$M_{Rd,B}$ [kNm]							
180	-27.4 16.1	-29.5 18.8	-23.3 16.1	-25.4 18.8	-22.0 16.1	-24.1 18.8	-20.6 16.1	-22.7 18.8	-20.3 16.1	-22.4 18.8
200	-32.5 18.7	-35.0 22.0	-27.9 18.7	-30.4 22.0	-26.4 18.7	-28.9 22.0	-24.8 18.7	-27.3 22.0	-24.5 18.7	-27.0 22.0
220	-37.1 21.5	-40.4 25.2	-32.0 21.5	-35.3 25.2	-30.3 21.5	-33.6 25.2	-28.6 21.5	-32.0 25.2	-28.2 21.5	-31.6 25.2
240	-41.4 24.2	-45.7 28.4	-35.8 24.2	-40.1 28.4	-33.9 24.2	-38.3 28.4	-32.1 24.2	-36.4 28.4	-31.6 24.2	-36.0 28.4
260	-45.6 26.9	-50.3 31.6	-39.5 26.9	-44.2 31.6	-37.5 26.9	-42.1 31.6	-35.4 26.9	-40.1 31.6	-35.0 26.9	-39.6 31.6
280	-49.7 29.7	-54.7 34.8	-43.2 29.7	-48.2 34.8	-41.0 29.7	-46.1 34.8	-38.9 29.7	-43.9 34.8	-38.4 29.7	-43.4 34.8

Load bearing capacity values for further types and for concrete strength C30/37 can be found in the type tests at www.halfen.com or on request. See back cover for contact information.



The verification can be performed either in section A-A or in section B-B.

HALFEN HIT STEEL TO CONCRETE CONNECTOR HIT-HP SDV

Resistance at ultimate load capacity



Shear capacity / Moment bearing capacity

Concrete strength: C20/25 ≥ C25/30



HIT-HP SDV 2M22-0212	Section A-A V _{Rd,A} [kN]		Section B-B for selected shear load V _{Rd,B} [kN]								M22
	Design values	75.3	75.3	50.0	50.0	60.0	60.0	70.0	70.0	75.3	
Element height [mm]	M _{Rd,A} [kNm]		M _{Rd,B} [kNm]								
180	-27.4	-29.5	-20.6	-22.7	-19.2	-21.3	-17.9	-20.0	-17.2	-19.3	
	16.1	18.8	16.1	18.8	16.1	18.8	16.1	18.8	16.1	18.8	
200	-32.5	-35.0	-24.8	-27.3	-23.3	-25.8	-21.8	-24.3	-21.0	-23.5	
	18.7	22.0	18.7	22.0	18.7	22.0	18.7	22.0	18.7	22.0	
220	-37.1	-40.4	-28.6	-32.0	-26.9	-30.3	-25.2	-28.6	-24.3	-27.7	
	21.5	25.2	21.5	25.2	21.5	25.2	21.5	25.2	21.5	25.2	
240	-41.4	-45.7	-32.1	-36.4	-30.2	-34.5	-28.3	-32.7	-27.4	-31.7	
	24.2	28.4	24.2	28.4	24.2	28.4	24.2	28.4	24.2	28.4	
260	-45.6	-50.3	-35.4	-40.1	-33.4	-38.1	-31.4	-36.1	-30.3	-35.0	
	26.9	31.6	26.9	31.6	26.9	31.6	26.9	31.6	26.9	31.6	
280	-49.7	-54.7	-38.9	-43.9	-36.7	-41.7	-34.6	-39.6	-33.4	-38.4	
	29.7	34.8	29.7	34.8	29.7	34.8	29.7	34.8	29.7	34.8	

Load bearing capacity values for further types and for concrete strength C30/37 can be found in the type tests at www.halfen.com or on request. See back cover for contact information.

Resistance at ultimate load capacity



Shear capacity / Moment bearing capacity

Concrete strength: C20/25 ≥ C25/30



HIT-SP SDV 2M16-0208	Section A-A V _{Rd,A} [kN]		Section B-B for selected shear load V _{Rd,B} [kN]								M16
	Design values	28.1	28.1	10.0	10.0	20.0	20.0	25.0	25.0	28.1	
Element height [mm]	M _{Rd,A} [kNm]		M _{Rd,B} [kNm]								
180	-13.9	-15.1	-12.0	-13.3	-10.2	-11.5	-9.3	-10.6	-8.7	-10.0	
	12.5	14.7	12.5	14.7	12.5	14.7	12.5	14.7	12.5	14.7	
200	-16.0	-17.8	-13.9	-15.7	-11.8	-13.7	-10.8	-12.6	-10.2	-12.0	
	14.6	17.1	14.6	17.1	14.6	17.1	14.6	17.1	14.6	17.1	
220	-18.1	-20.5	-15.8	-18.2	-13.5	-15.9	-12.3	-14.7	-11.6	-14.0	
	16.7	19.5	16.7	19.5	16.7	19.5	16.7	19.5	16.7	19.5	
240	-20.2	-23.2	-17.6	-20.6	-15.1	-18.1	-13.8	-16.8	-13.0	-16.0	
	18.8	22.0	18.8	22.0	18.8	22.0	18.8	22.0	18.8	22.0	
260	-22.3	-25.8	-19.5	-23.1	-16.7	-20.3	-15.3	-18.9	-14.5	-18.0	
	20.9	24.4	20.9	24.4	20.9	24.4	20.9	24.4	20.9	24.4	
280	-24.4	-28.4	-21.3	-25.4	-18.3	-22.4	-16.8	-20.9	-15.9	-20.0	
	23.0	26.9	23.0	26.9	23.0	26.9	23.0	26.9	23.0	26.9	

Load bearing capacity values for further types and for concrete strength C30/37 can be found in the type tests at www.halfen.com or on request. See back cover for contact information.



The verification can be performed either in section A-A or in section B-B.

HALFEN HIT STEEL TO CONCRETE CONNECTOR HIT-SP SDV

Resistance at ultimate load capacity



Shear capacity / Moment bearing capacity

Concrete strength: C20/25 ≥ C25/30



HIT-SP SDV 2M16-0210	Section A-A $V_{Rd,A}$ [kN]		Section B-B for selected shear load $V_{Rd,B}$ [kN]							
Design values	43.9	43.9	25.0	25.0	30.0	30.0	40.0	40.0	43.9	43.9
Element height [mm]	$M_{Rd,A}$ [kNm]		$M_{Rd,B}$ [kNm]							
180	-13.9 12.5	-15.1 14.7	-9.3 12.5	-10.6 14.7	-8.4 12.5	-9.7 14.7	-6.6 12.5	-7.8 14.7	-5.8 12.5	-7.1 14.7
200	-16.0 14.6	-17.8 17.1	-10.8 14.6	-12.6 17.1	-9.8 14.6	-11.6 17.1	-7.7 14.6	-9.6 17.1	-6.9 14.6	-8.7 17.1
220	-18.1 16.7	-20.5 19.5	-12.3 16.7	-14.7 19.5	-11.2 16.7	-13.6 19.5	-8.9 16.7	-11.3 19.5	-8.0 16.7	-10.4 19.5
240	-20.2 18.8	-23.2 22.0	-13.8 18.8	-16.8 22.0	-12.5 18.8	-15.5 22.0	-10.0 18.8	-13.0 22.0	-9.0 18.8	-12.0 22.0
260	-22.3 20.9	-25.8 24.4	-15.3 20.9	-18.9 24.4	-13.9 20.9	-17.5 24.4	-11.1 20.9	-14.7 24.4	-10.1 20.9	-13.6 24.4
280	-24.4 23.0	-28.4 26.9	-16.8 23.0	-20.9 26.9	-15.3 23.0	-19.4 26.9	-12.3 23.0	-16.4 26.9	-11.1 23.0	-15.2 26.9

Load bearing capacity values for further types and for concrete strength C30/37 can be found in the type tests at www.halfen.com or on request. See back cover for contact information.

HIT-SP SDV 2M22-0208	Section A-A $V_{Rd,A}$ [kN]		Section B-B for selected shear load $V_{Ed,B}$ [kN]							
Design values	28.1	28.1	10.0	10.0	20.0	20.0	25.0	25.0	28.1	28.1
Element height [mm]	$M_{Rd,A}$ [kNm]		$M_{Rd,B}$ [kNm]							
180	-27.4 16.1	-29.5 18.8	-25.6 16.1	-27.7 18.8	-23.9 16.1	-26.0 18.8	-23.0 16.1	-25.1 18.8	-22.4 16.1	-24.5 18.8
200	-32.5 18.7	-35.0 22.0	-30.5 18.7	-33.0 22.0	-28.4 18.7	-30.9 22.0	-27.4 18.7	-29.9 22.0	-26.8 18.7	-29.3 22.0
220	-37.1 21.5	-40.4 25.2	-34.8 21.5	-38.2 25.2	-32.6 21.5	-35.9 25.2	-31.4 21.5	-34.8 25.2	-30.7 21.5	-34.1 25.2
240	-41.4 24.2	-45.7 28.4	-38.9 24.2	-43.2 28.4	-36.4 24.2	-40.7 28.4	-35.2 24.2	-39.5 28.4	-34.4 24.2	-38.7 28.4
260	-45.6 26.9	-50.3 31.6	-42.9 26.9	-47.5 31.6	-40.1 26.9	-44.8 31.6	-38.8 26.9	-43.4 31.6	-37.9 26.9	-42.6 31.6
280	-49.7 29.7	-54.7 34.8	-46.8 29.7	-51.8 34.8	-43.9 29.7	-48.9 34.8	-42.4 29.7	-47.4 34.8	-41.5 29.7	-46.5 34.8

Load bearing capacity values for further types and for concrete strength C30/37 can be found in the type tests at www.halfen.com or on request. See back cover for contact information.



The verification can be performed either in section A-A or in section B-B.

HALFEN HIT STEEL TO CONCRETE CONNECTOR HIT-SP SDV

Resistance at ultimate load capacity



Shear capacity / Moment bearing capacity

Concrete strength: C20/25 ≥ C25/30



HIT-SP SDV 2M22-0210	Section A-A $V_{Rd,A}$ [kN]		Section B-B for selected shear load $V_{Rd,B}$ [kN]								M22
	43.9	43.9	25.0	25.0	30.0	30.0	40.0	40.0	43.9	43.9	
Design values	43.9	43.9	25.0	25.0	30.0	30.0	40.0	40.0	43.9	43.9	
Element height [mm]	$M_{Rd,A}$ [kNm]		$M_{Rd,B}$ [kNm]								
180	-27.4	-29.5	-23.0	-25.1	-22.1	-24.2	-20.3	-22.4	-19.6	-21.7	
	16.1	18.8	16.1	18.8	16.1	18.8	16.1	18.8	16.1	18.8	
200	-32.5	-35.0	-27.4	-29.9	-26.4	-28.9	-24.4	-26.9	-23.6	-26.1	
	18.7	22.0	18.7	22.0	18.7	22.0	18.7	22.0	18.7	22.0	
220	-37.1	-40.4	-31.4	-34.8	-30.3	-33.7	-28.0	-31.4	-27.2	-30.5	
	21.5	25.2	21.5	25.2	21.5	25.2	21.5	25.2	21.5	25.2	
240	-41.4	-45.7	-35.2	-39.5	-33.9	-38.3	-31.4	-35.8	-30.5	-34.8	
	24.2	28.4	24.2	28.4	24.2	28.4	24.2	28.4	24.2	28.4	
260	-45.6	-50.3	-38.8	-43.4	-37.4	-42.1	-34.7	-39.4	-33.6	-38.3	
	26.9	31.6	26.9	31.6	26.9	31.6	26.9	31.6	26.9	31.6	
280	-49.7	-54.7	-42.4	-47.4	-41.0	-46.0	-38.0	-43.1	-36.9	-41.9	
	29.7	34.8	29.7	34.8	29.7	34.8	29.7	34.8	29.7	34.8	

Load bearing capacity values for further types and for concrete strength C30/37 can be found in the type tests at www.halfen.com or on request. See back cover for contact information.

HIT-SP SDV 2M22-0212	Section A-A $V_{Rd,A}$ [kN]		Section B-B for selected shear load $V_{Rd,B}$ [kN]								M22
	59.0	59.0	40.0	40.0	50.0	50.0	55.0	55.0	59.0	59.0	
Design values	59.0	59.0	40.0	40.0	50.0	50.0	55.0	55.0	59.0	59.0	
Element height [mm]	$M_{Rd,A}$ [kNm]		$M_{Rd,B}$ [kNm]								
180	-27.4	-29.5	-20.3	-22.4	-18.5	-20.6	-17.6	-19.7	-16.9	-19.0	
	16.1	18.8	16.1	18.8	16.1	18.8	16.1	18.8	16.1	18.8	
200	-32.5	-35.0	-24.4	-26.9	-22.4	-24.9	-21.4	-23.9	-20.6	-23.1	
	18.7	22.0	18.7	22.0	18.7	22.0	18.7	22.0	18.7	22.0	
220	-37.1	-40.4	-28.0	-31.4	-25.8	-29.2	-24.7	-28.0	-23.8	-27.1	
	21.5	25.2	21.5	25.2	21.5	25.2	21.5	25.2	21.5	25.2	
240	-41.4	-45.7	-31.4	-35.8	-28.9	-33.3	-27.7	-32.0	-26.7	-31.0	
	24.2	28.4	24.2	28.4	24.2	28.4	24.2	28.4	24.2	28.4	
260	-45.6	-50.3	-34.7	-39.4	-32.0	-36.6	-30.6	-35.3	-29.5	-34.2	
	26.9	31.6	26.9	31.6	26.9	31.6	26.9	31.6	26.9	31.6	
280	-49.7	-54.7	-38.0	-43.1	-35.1	-40.1	-33.7	-38.7	-32.5	-37.5	
	29.7	34.8	29.7	34.8	29.7	34.8	29.7	34.8	29.7	34.8	

Load bearing capacity values for further types and for concrete strength C30/37 can be found in the type tests at www.halfen.com or on request. See back cover for contact information.



The verification can be performed either in section A-A or in section B-B.

HALFEN HIT STEEL TO CONCRETE CONNECTOR HIT-HP SDV, HIT-SP SDV

Product specifications HIT-HP/SP SDV-2M16

HIT-HP/SP SDV-2M16-0208 with installation aid

Section

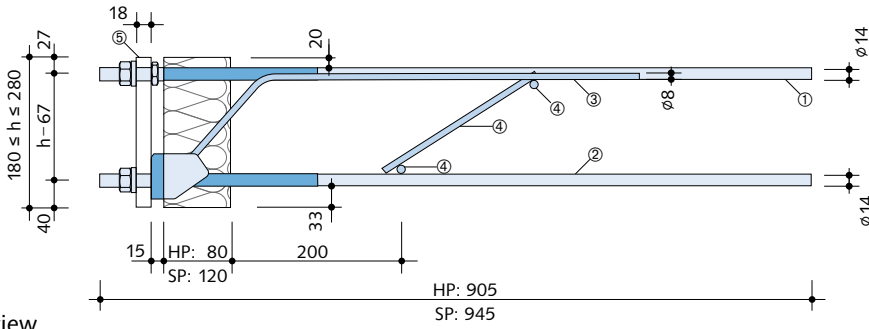

Plan view

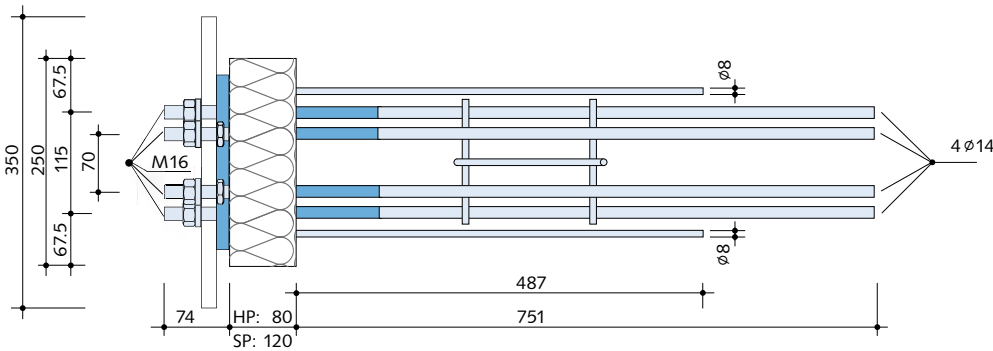

- ① Tension bar
- ② Compression bar
- ③ Shear bar
- ④ Constructive installation rebar
- ⑤ Installation aid

Dimensions in [mm]

HIT-HP/SP SDV-2M16-0210 with installation aid

Section

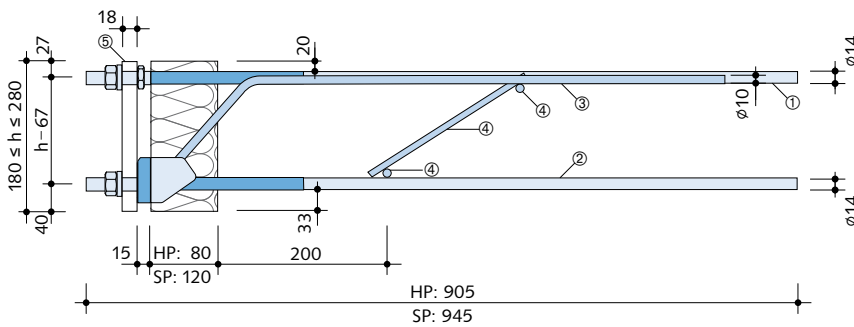

Plan view

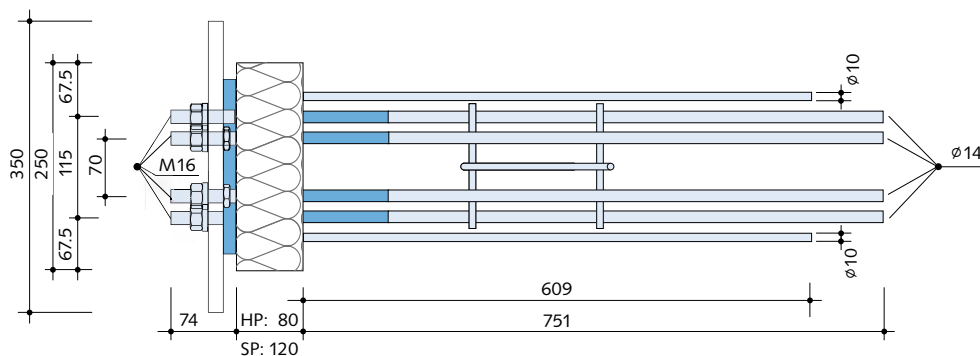

- ① Tension bar
- ② Compression bar
- ③ Shear bar
- ④ Constructive installation rebar
- ⑤ Installation aid

Dimensions in [mm]

HALFEN HIT STEEL TO CONCRETE CONNECTOR

HIT-HP SDV, HIT-SP SDV

Product specifications HIT-HP/SP SDV-2M22

HIT-HP/SP SDV-2M22-0208 and HIT-HP/SP SDV-2M22-0210 with installation aid

Section

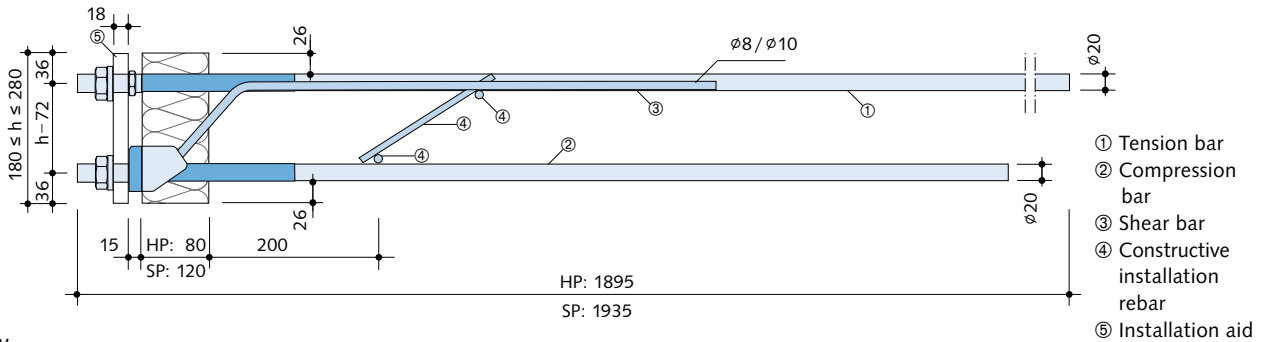

Plan view

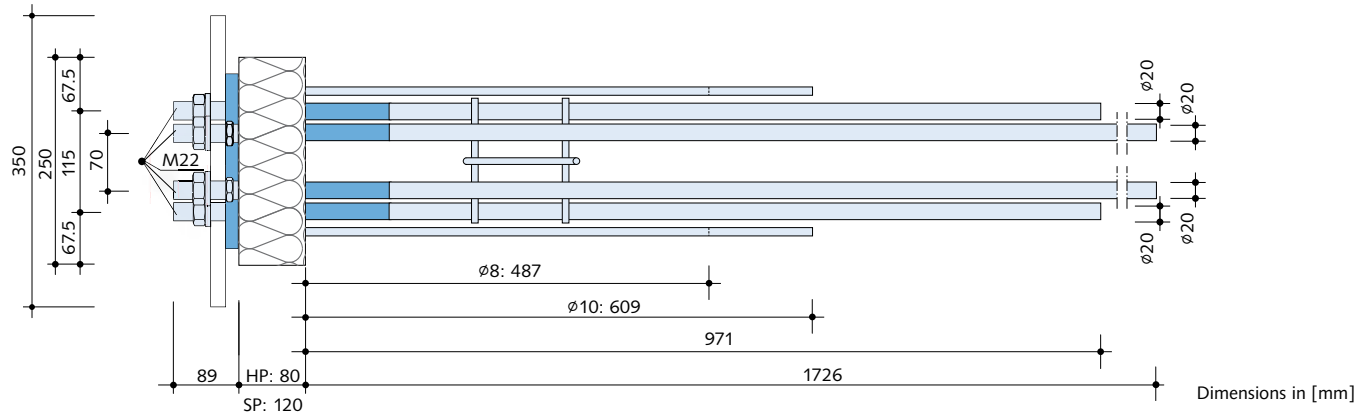

HIT-HP/SP SDV-2M22-0212 with installation aid

Section

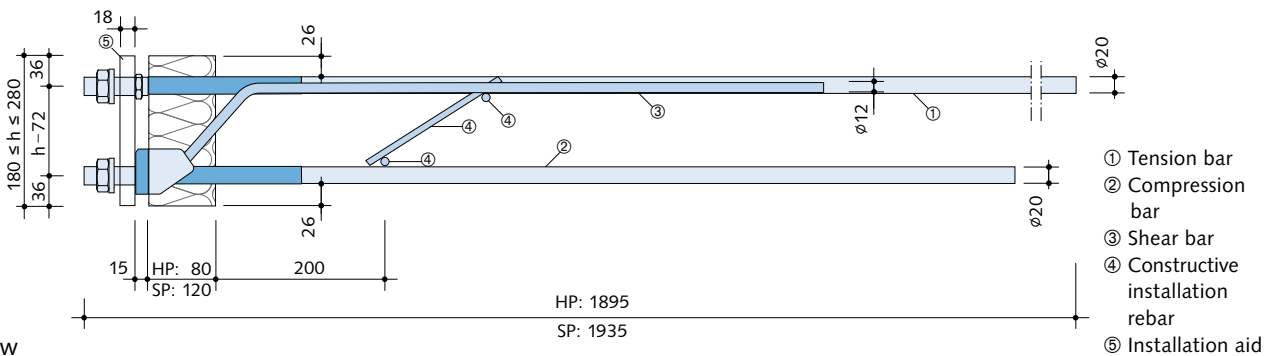

Plan view

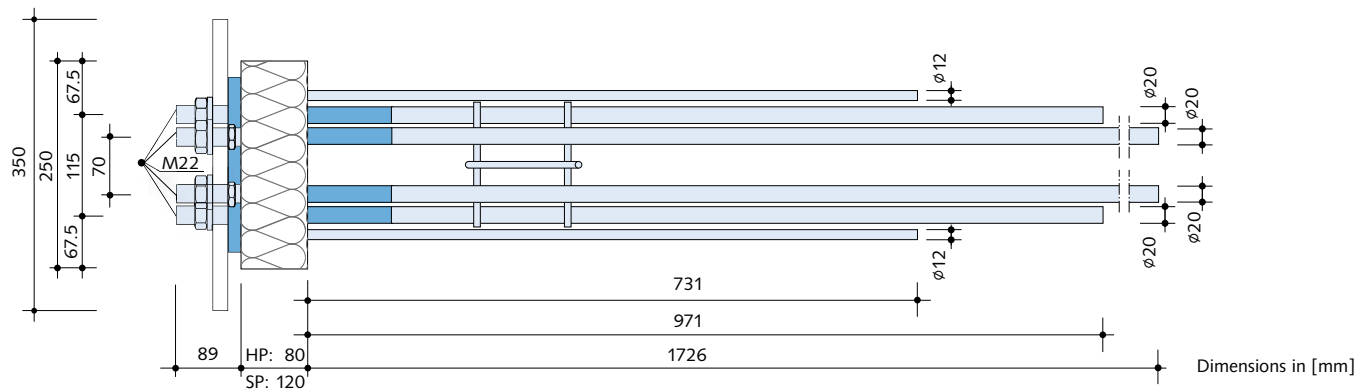

HALFEN HIT STEEL TO CONCRETE CONNECTOR HIT-HP SDV, HIT-SP SDV

On-site reinforcement HIT-HP/SP SDV-2M16

Section

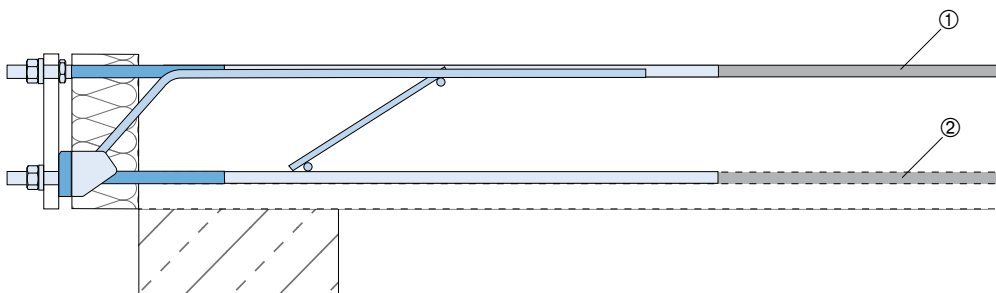

Plan view

Figure: Overlap with on-site reinforcement

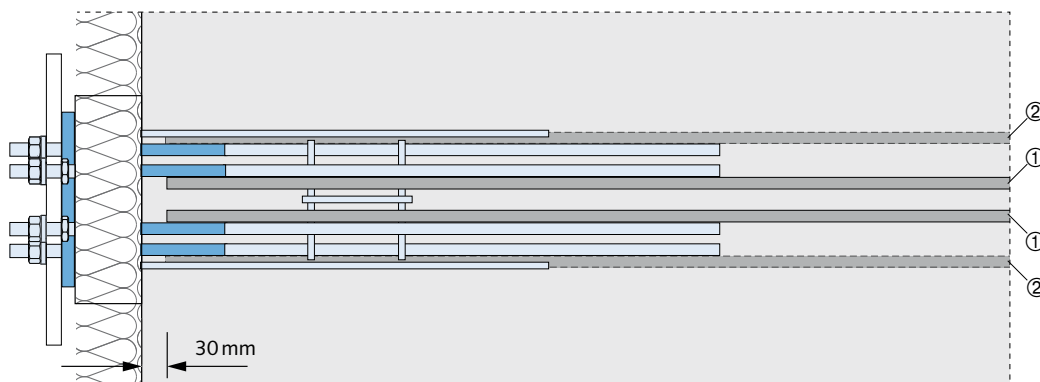

Position ①: $\geq 2\phi 14$; The length of the bars is derived from the tension bar overlap according to the structural design plans.

Position ②: $\geq 2\phi 14$; Only required for lifting moments.

The length of the bars is derived from the tension bar overlap according to the structural design plans.



On-site reinforcement according to the structural engineer's specifications.



Constructive reinforcement for the free slab edge in accordance with EN 1992-1-1

HALFEN HIT STEEL TO CONCRETE CONNECTOR HIT-HP SDV, HIT-SP SDV

On-site reinforcement HIT-HP/SP SDV-2M22

Section

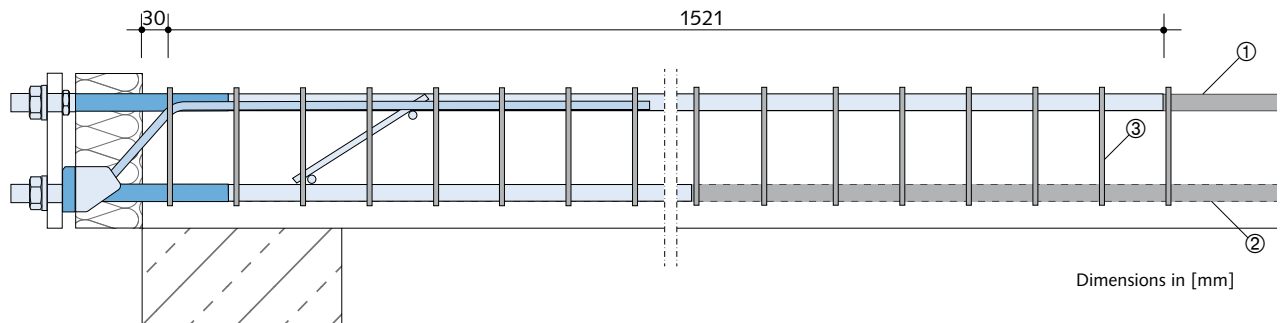

Plan view

Figure: Overlap with on-site reinforcement

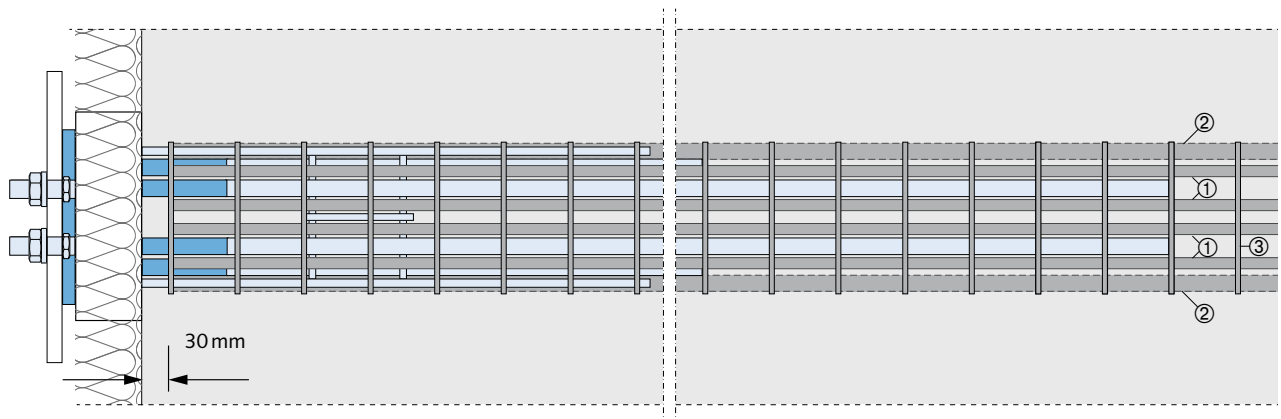

Position ①: $\geq 4\phi 14$; The length of the bars is derived from the tension bar overlap according to the structural design plans.

Position ②: $\geq 4\phi 14$; Only required for lifting moments.

Number, diameter and length of the bars according to the structural design plans.

Position ③: Stirrups $\geq 20\phi 6$; spacing $s = 80$ mm

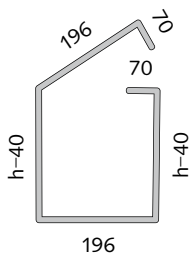

Dimensions, stirrups (20 at $\phi 6$ mm)

Dimensions in [mm]



Stirrup layout according to EN 1992-1-1; 8.7.4.2



Constructive reinforcement for the free slab edge in accordance with EN 1992-1-1

HALFEN HIT STEEL TO CONCRETE CONNECTOR

HIT-HP SDV, HIT-SP SDV

Deformation

For the HIT-HP/SP SDV elements, the torsional deformations resulting from elastic formwork deformation in the insulation/load inducement joint area α_M are assumed due to a standard effective moment of $M_{Ed} = 1 \text{ kNm}$.

The required camber to compensate for elastic deformations of the connected steel structure can be approximated as follows:

$$\ddot{u} = \alpha_M \cdot l_k \cdot M_{Ed}$$

- with \ddot{u} = Camber [mm]
 α_M = Torque resulting from $M_{Ed} = 1 \text{ kNm}$;
 Table values in [%/kNm]
 l_k = Span distance, cantilever beam [m]
 M_{Ed} = Design value of the effective moments [kNm]
 at serviceability limit state (SLS)

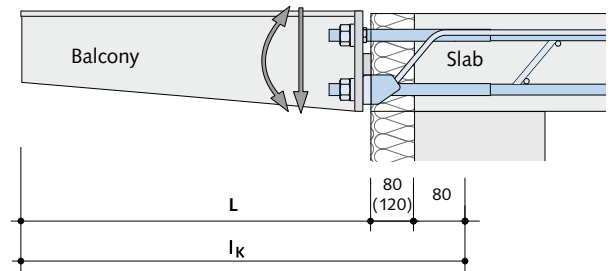

L = Cantilever length [m]
 l_k = Span distance, cantilever beam [m]

Other deformation factors resulting from deformation of the connected steel structure must be considered by the structural engineer when determining the overall camber. The α_M values [%/kNm] in the following table are in accordance with approval no. Z-15.7-336

HIT-HP SDV

Element height h [mm]	HP SDV-2M16-0208 HP SDV-2M16-0210	HP SDV-2M22-0208 HP SDV-2M22-0210 HP SDV-2M22-0212
180	0.885	0.572
200	0.639	0.407
220	0.483	0.305
240	0.378	0.236
260	0.304	0.189
280	0.249	0.154

HIT-SP SDV

Element height h [mm]	SP SDV-2M16-0208 SP SDV-2M16-0210	SP SDV-2M22-0208 SP SDV-2M22-0210 SP SDV-2M22-0212
180	1.003	0.639
200	0.724	0.455
220	0.547	0.340
240	0.428	0.264
260	0.344	0.211
280	0.282	0.172

HALFEN HIT STEEL TO CONCRETE CONNECTOR HIT-HP SDV, HIT-SP SDV

Torsion spring stiffnesses

HIT-HP SDV

Torsion spring C [kNm/rad] for element height h [mm]	HP SDV-2M16-0208 HP SDV-2M16-0210	HP SDV-2M22-0208 HP SDV-2M22-0210 HP SDV-2M22-0212
180	1184	1814
200	1640	2548
220	2170	3406
240	2775	4389
260	3454	5497
280	4207	6728

HIT-SP SDV

Torsion spring C [kNm/rad] for element height h [mm]	SP SDV-2M16-0208 SP SDV-2M16-0210	SP SDV-2M22-0208 SP SDV-2M22-0210 SP SDV-2M22-0212
180	1049	1631
200	1453	2291
220	1923	3063
240	2459	3946
260	3060	4942
280	3728	6049

HALFEN HIT STEEL TO CONCRETE CONNECTOR HIT-HP SDV, HIT-SP SDV

Axial spacing

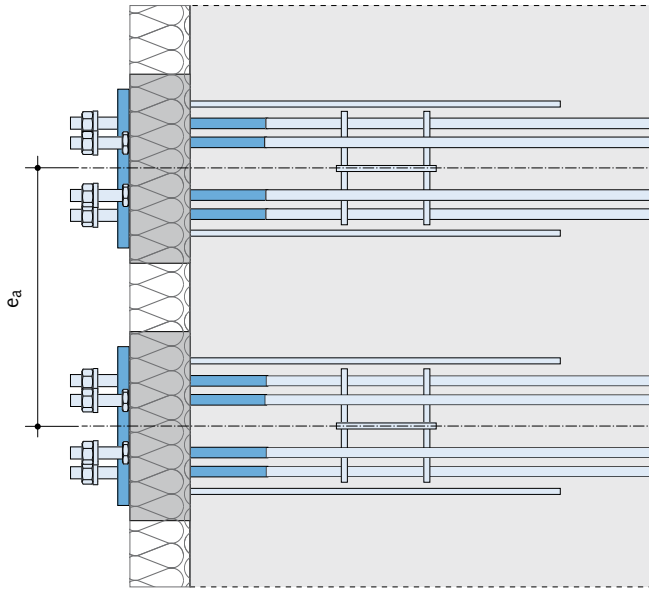

HIT Type	axial spacing $e_a \geq$ [mm]
HIT-HP SDV	250*
HIT-SP SDV	250*

*Custom elements with smaller spacings on request

Edge distance

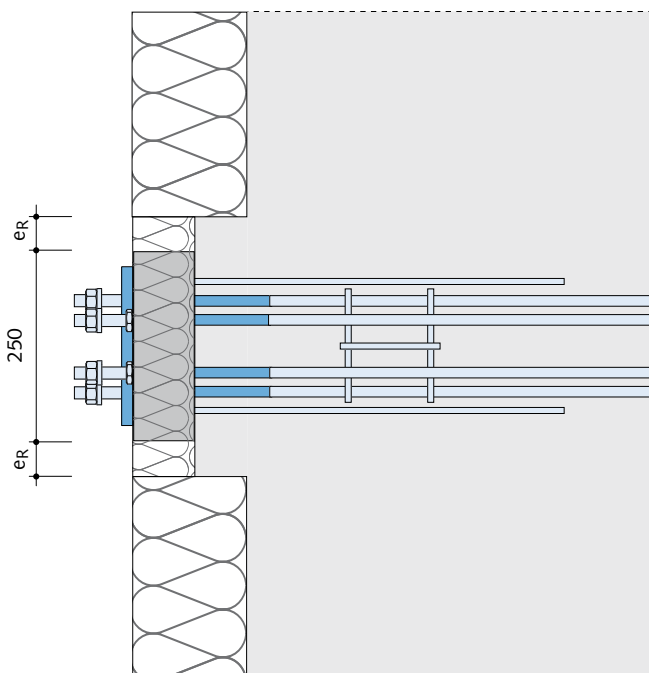

HIT Type	Distance e_R [mm]
HIT-HP SDV-2M16-0208	11
HIT-HP SDV-2M16-0210	22
HIT-HP SDV-2M22-0208	11
HIT-HP SDV-2M22-0210	22
HIT-HP SDV-2M22-0212	33
HIT-SP SDV-2M16-0208	11
HIT-SP SDV-2M16-0210	22
HIT-SP SDV-2M22-0208	11
HIT-SP SDV-2M22-0210	22
HIT-SP SDV-2M22-0212	33

HALFEN HIT STEEL TO CONCRETE CONNECTOR HIT-HP SDV, HIT-SP SDV

Distance from an outer corner

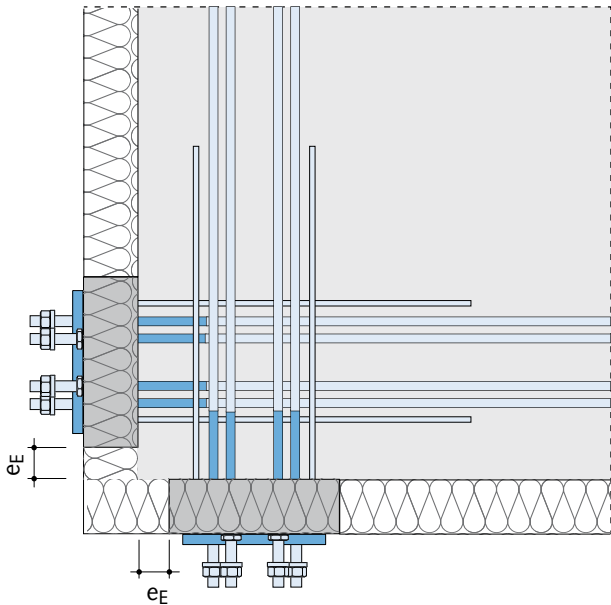

HIT Type	Distance e_E [mm]
HIT-HP SDV-2M16-0208	11
HIT-HP SDV-2M16-0210	22
HIT-HP SDV-2M22-0208	11
HIT-HP SDV-2M22-0210	22
HIT-HP SDV-2M22-0212	33
HIT-SP SDV-2M16-0208	11
HIT-SP SDV-2M16-0210	22
HIT-SP SDV-2M22-0208	11
HIT-SP SDV-2M22-0210	22
HIT-SP SDV-2M22-0212	33

To install the HIT-SDV elements at an external corner, it is necessary to offset the installation height of the elements. The required height offset is achieved using 20 mm insulation strips (not included).

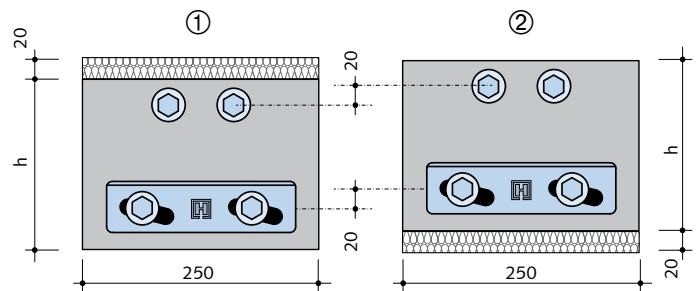
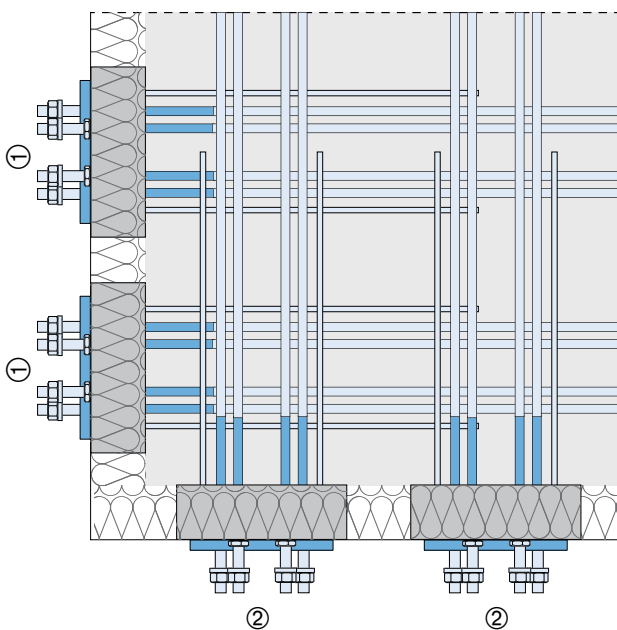

HIT-SDV 2M22: No tolerances are considered in the 20 mm height offset. We therefore recommend an offset of 25 mm for these types.

HALFEN HIT STEEL TO CONCRETE CONNECTOR HIT-HP SDV, HIT-SP SDV

Installation instructions concrete

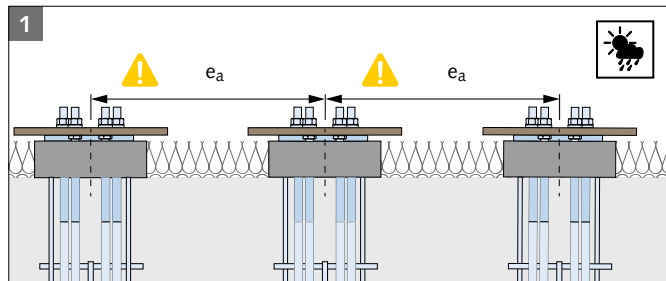

- 1 Installing the bottom reinforcement layer (example, mesh reinforcement).**
Installing the HIT Element from above.

Install the HIT Element with increased accuracy as the steel construction is post-installed!

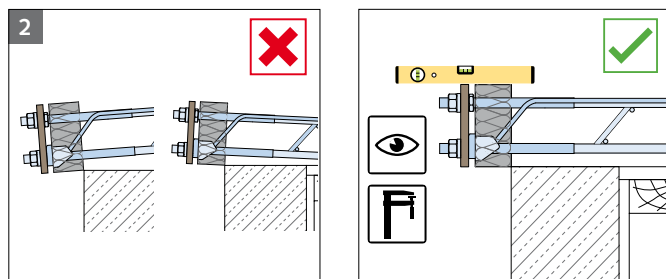

- 2 Accurate installation**

Ensure installation is exactly horizontal and vertical!

Ensure the formwork is installed at the correct height!

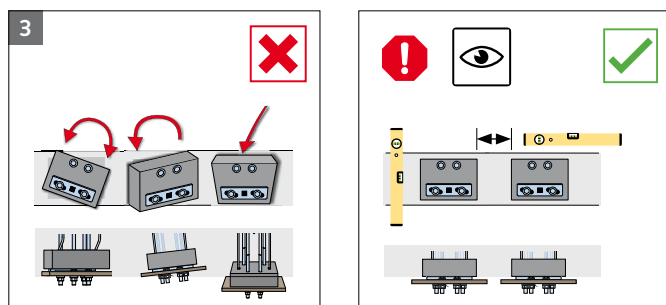

- 3 Checking horizontal and vertical alignment**

The included (wood) installation aids are used to precisely align the elements; the overhanging edges can be used to fix to the on-site formwork as required.

Alternative: Make installation aids on-site (for example, in wood or U-profiles). Use the supplied installation aids or alternatively our drilling templates to transfer the drill hole sizes and element distances to the on-site made installation aids.

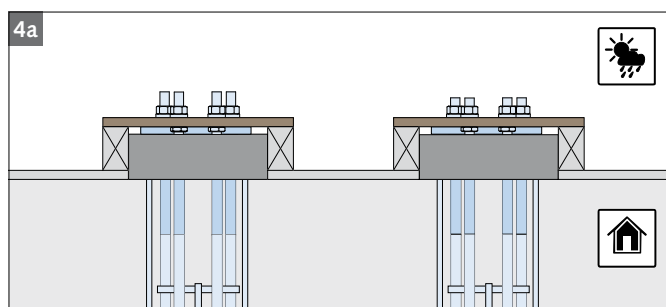

- 4 Installing the formwork**

- a** Concreting directly against the formwork

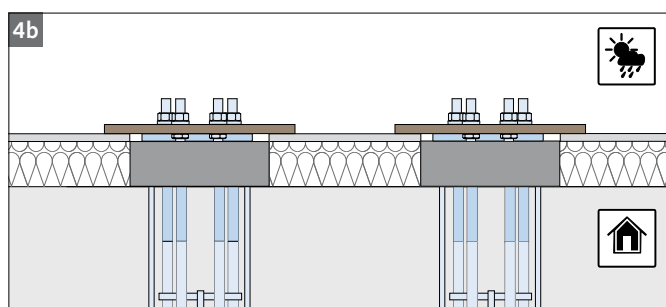

- b** Concreting directly against the insulation

A free drilling template (.pdf file) is available at:
 ▶ www.halfen.com ▶ Product Ranges ▶ Construction
 ▶ Reinforcement systems ▶ HIT Steel to Concrete Connector
 ▶ Product Information ▶ Installation Instructions

HALFEN HIT STEEL TO CONCRETE CONNECTOR HIT-HP SDV, HIT-SP SDV

Installation in concrete

5a HIT-HP/SP SDV-2M16

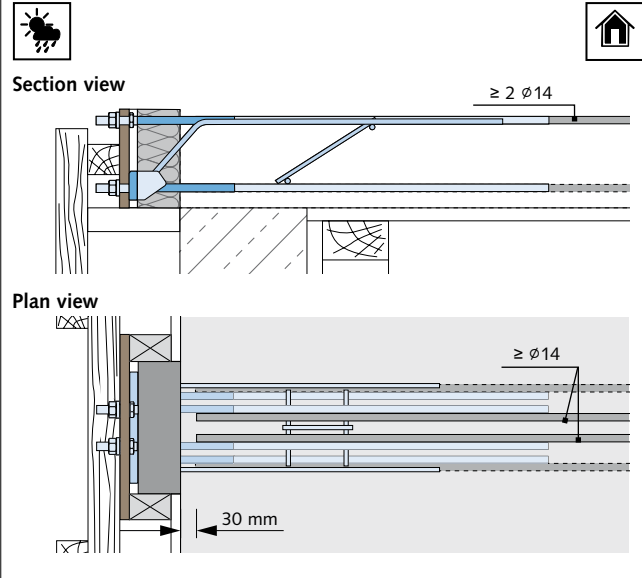

5 Installing the on-site reinforcement

a Installing the on-site reinforcement for HIT-HP/SP SDV-2M16

! On-site reinforcement must be placed as specified by the structural engineer.

i Structural reinforcement of the slab free edge according to EN 1992-1-1

5b HIT-HP/SP SDV-2M22

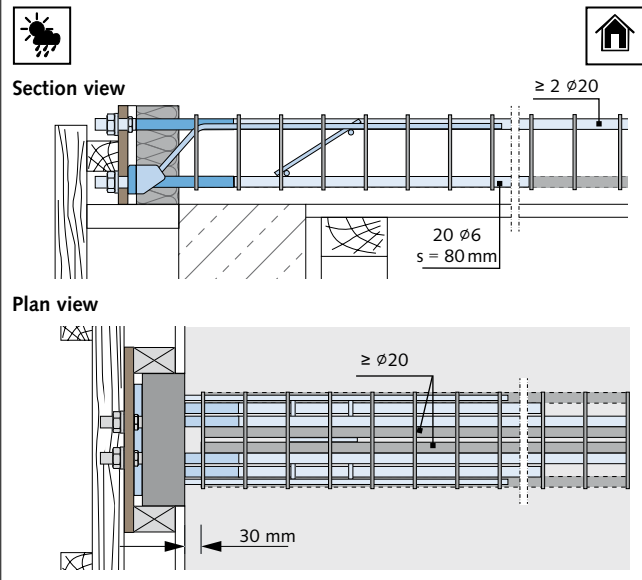

b Installing the on-site reinforcement for HIT-HP/SP SDV-2M22

! On-site reinforcement must be placed as specified by the structural engineer.

i Structural reinforcement of the slab free edge according to EN 1992-1-1

i Stirrup layout in accordance with EN 1992-1-1; 8.7.4.2

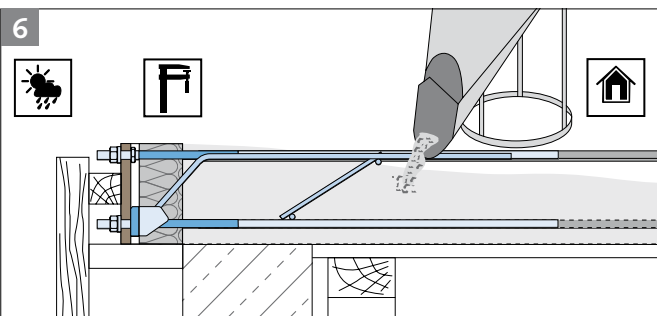

6 Pouring the concrete

! To ensure the HIT units are not displaced, ensure the concrete is poured and compacted evenly.

HALFEN HIT STEEL TO CONCRETE CONNECTOR HIT-HP SMV, HIT-SP SMV

2

- > Element for connecting steel constructions to reinforced concrete structures
- > Transfer of negative bending moments and positive shear loads

TYPE TESTED

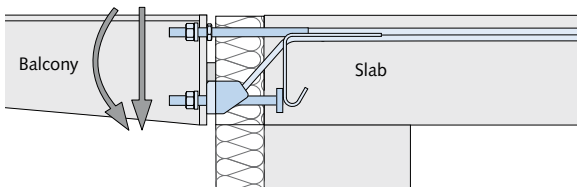

HIT-HP SMV – High Performance with 80 mm insulation
HIT-SP SMV – Superior Performance with 120 mm insulation

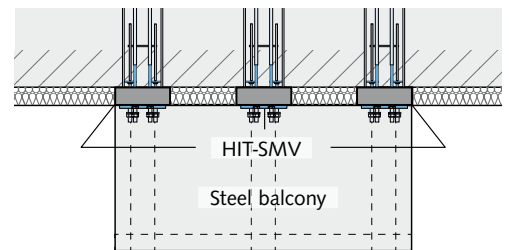

Application: Cantilever balcony

Contents	Type	Page
Load capacity range	HIT-HP SMV, HIT-SP SMV	32
Load capacity values	HIT-HP SMV, HIT-SP SMV	33
Product description	HIT-HP SMV, HIT-SP SMV	35
On-site connecting reinforcement	HIT-HP SMV, HIT-SP SMV	36
Deformation	HIT-HP SMV, HIT-SP SMV	37
Torsion spring stiffnesses	HIT-HP SMV, HIT-SP SMV	38
Axial spacing	HIT-HP SMV, HIT-SP SMV	39
Installation instructions	HIT-HP SMV, HIT-SP SMV	41

HALFEN HIT STEEL TO CONCRETE CONNECTOR HIT-HP SMV, HIT-SP SMV

Load capacity range

Combinations of one moment and two shear load ranges are available. The following combinations of tension bars, anchor head compression bars and shear load bars are available for HIT-HP 80 mm and HIT-SP 120 mm insulation thickness.

Element width B = 25 cm

Number and diameter of the connection bolts; balcony side	Number and diameter of the tension bars; main slab	Number and diameter of the shear load bars	
		2 \varnothing 8	2 \varnothing 10
2M16	2 \varnothing 14	●	●

See the following pages for load capacity values for selected elements ● = HP and SP

Basic types – ordering examples

Ordering example

HIT-HP	SMV	-	2M16	-	0208	-	18
HIT-SP	SMV	-	2M16	-	0210	-	28
①	②	③	④	⑤	⑥		

Type designation

- ① Product group
- ② Joint spacing 80 mm (HP) or 120 mm (SP)
- ③ Connection type
- ④ Moment load range
- ⑤ Shear load range
- ⑥ Element height [cm]



CUSTOM SOLUTIONS

HALFEN HIT Insulated connections
Our technical support team is available if a custom solution is required for your project.
Contact details: → see back cover of catalogue

Technical data

Element description HIT-HP/HIT-SP	Possible Element height h [mm]	Balcony side	Main slab side				min. concrete cover slab side [mm]	
		Thread	Tension rods [mm]	Compression rods	Shear load rods [mm]	Stirrups [mm]	$c_{v,top}$	$c_{v,bottom}$
SMV-2M16-0208	180-280	2 M16	2 \varnothing 14	Anchor head	2 \varnothing 8	2 \varnothing 8	20	33
SMV-2M16-0210		2 M16	2 \varnothing 14	Anchor head	2 \varnothing 10	2 \varnothing 8	20	33

HALFEN HIT STEEL TO CONCRETE CONNECTOR

HIT-HP SMV, HIT-SP SMV

Resistance at ultimate load capacity



Shear capacity / Moment bearing capacity

Concrete strength: C20/25 \geq C25/30



HIT-HP SMV 2M16-0208	Section A-A $V_{Rd,A}$ [kN]		Section B-B for selected shear load $V_{Rd,B}$ [kN]							
	33.5	33.5	10.0	10.0	20.0	20.0	30.0	30.0	33.5	33.5
Element height [mm]	$M_{Rd,A}$ [kNm]		$M_{Rd,B}$ [kNm]							
180	-13.6	-15.1	-12.2	-13.7	-10.8	-12.3	-9.4	-10.9	-9.0	-10.5
200	-16.0	-17.8	-14.4	-16.2	-12.8	-14.7	-11.3	-13.1	-10.7	-12.6
220	-18.1	-20.5	-16.3	-18.8	-14.6	-17.0	-12.9	-15.3	-12.3	-14.7
240	-20.2	-23.2	-18.3	-21.3	-16.4	-19.4	-14.5	-17.5	-13.8	-16.8
260	-22.3	-25.8	-20.2	-23.8	-18.1	-21.7	-16.1	-19.6	-15.3	-18.9
280	-24.4	-28.4	-22.1	-26.2	-19.9	-24.0	-17.7	-21.7	-16.9	-21.0

Load bearing capacity values for further types and for concrete strength C30/37 can be found in the type tests at www.halfen.com or on request. See back cover for contact information.

HIT-HP SMV 2M16-0210	Section A-A $V_{Rd,A}$ [kN]		Section B-B for selected shear load $V_{Rd,B}$ [kN]							
	52.3	52.3	30.0	30.0	40.0	40.0	50.0	50.0	52.3	52.3
Element height [mm]	$M_{Rd,A}$ [kNm]		$M_{Rd,B}$ [kNm]							
180	-13.6	-15.1	-9.4	-10.9	-8.1	-9.6	-6.7	-8.2	-6.3	-7.8
200	-16.0	-17.8	-11.3	-13.1	-9.7	-11.6	-8.1	-10.0	-7.8	-9.6
220	-18.1	-20.5	-12.9	-15.3	-11.1	-13.6	-9.4	-11.8	-9.0	-11.4
240	-20.2	-23.2	-14.5	-17.5	-12.6	-15.6	-10.7	-13.7	-10.2	-13.2
260	-22.3	-25.8	-16.1	-19.6	-14.0	-17.6	-11.9	-15.5	-11.5	-15.0
280	-24.4	-28.4	-17.7	-21.7	-15.4	-19.5	-13.2	-17.3	-12.7	-16.8

Load bearing capacity values for further types and for concrete strength C30/37 can be found in the type tests at www.halfen.com or on request. See back cover for contact information.



The verification can be performed either in section A-A or in section B-B.

HALFEN HIT STEEL TO CONCRETE CONNECTOR HIT-SP SMV

Resistance at ultimate load capacity



Shear capacity / Moment bearing capacity

Concrete strength: C20/25 ≥ C25/30



HIT-SP SMV 2M16-0208	Section A-A V _{Rd,A} [kN]		Section B-B for selected shear load V _{Rd,B} [kN]							
	28.1	28.1	10.0	10.0	20.0	20.0	25.0	25.0	28.1	28.1
Design values	28.1	28.1	10.0	10.0	20.0	20.0	25.0	25.0	28.1	28.1
Element height [mm]	M _{Rd,A} [kNm]		M _{Rd,B} [kNm]							
180	-13.6	-15.1	-11.8	-13.3	-10.0	-11.5	-9.1	-10.6	-8.5	-10.0
200	-16.0	-17.8	-13.9	-15.7	-11.8	-13.7	-10.8	-12.6	-10.2	-12.0
220	-18.1	-20.5	-15.8	-18.2	-13.5	-15.9	-12.3	-14.7	-11.6	-14.0
240	-20.2	-23.2	-17.6	-20.6	-15.1	-18.1	-13.8	-16.8	-13.0	-16.0
260	-22.3	-25.8	-19.5	-23.1	-16.7	-20.3	-15.3	-18.9	-14.5	-18.0
280	-24.4	-28.4	-21.3	-25.4	-18.3	-22.4	-16.8	-20.9	-15.9	-20.0

Load bearing capacity values for further types and for concrete strength C30/37 can be found in the type tests at www.halfen.com or on request. See back cover for contact information.

HIT-SP SMV 2M16-0210	Section A-A V _{Rd,A} [kN]		Section B-B for selected shear load V _{Rd,B} [kN]							
	43.9	43.9	25.0	25.0	30.0	30.0	40.0	40.0	43.9	43.9
Design values	43.9	43.9	25.0	25.0	30.0	30.0	40.0	40.0	43.9	43.9
Element height [mm]	M _{Rd,A} [kNm]		M _{Rd,B} [kNm]							
180	-13.6	-15.1	-9.1	-10.6	-8.2	-9.7	-6.3	-7.8	-5.6	-7.1
200	-16.0	-17.8	-10.8	-12.6	-9.8	-11.6	-7.7	-9.6	-6.9	-8.7
220	-18.1	-20.5	-12.3	-14.7	-11.2	-13.6	-8.9	-11.3	-8.0	-10.4
240	-20.2	-23.2	-13.8	-16.8	-12.5	-15.5	-10.0	-13.0	-9.0	-12.0
260	-22.3	-25.8	-15.3	-18.9	-13.9	-17.5	-11.1	-14.7	-10.1	-13.6
280	-24.4	-28.4	-16.8	-20.9	-15.3	-19.4	-12.3	-16.4	-11.1	-15.2

Load bearing capacity values for further types and for concrete strength C30/37 can be found in the type tests at www.halfen.com or on request. See back cover for contact information.



The verification can be performed either in section A-A or in section B-B.

HALFEN HIT STEEL TO CONCRETE CONNECTOR

HIT-HP SMV, HIT-SP SMV

Product description

HIT-HP/SP SMV-2M16-0208 with installation aid

Section

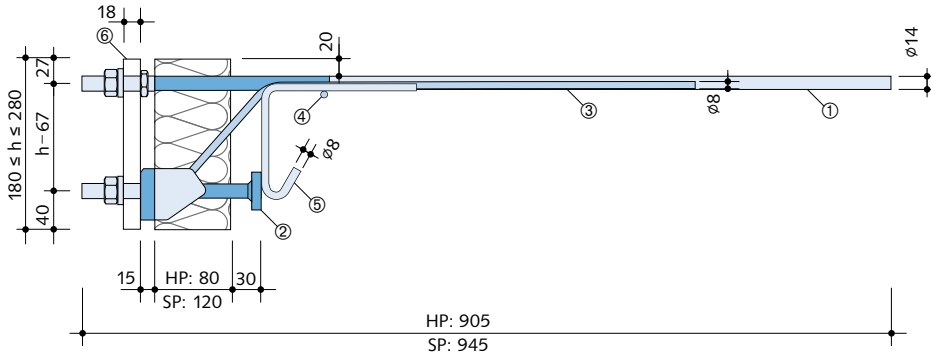

- ① Tension bar
- ② Pressure bearing
- ③ Shear load bar
- ④ Constructive installation rebar
- ⑤ Stirrup
- ⑥ Installation aid

Plan view

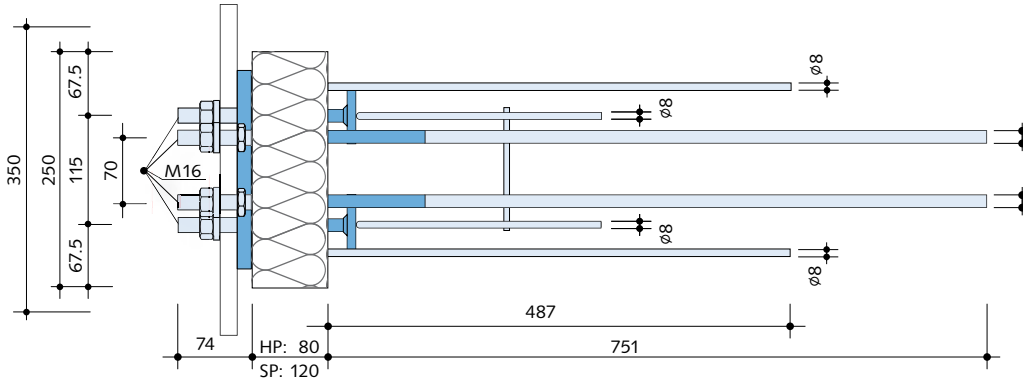

Dimensions in [mm]

HIT-HP/SP SMV-2M16-0210 with installation aid

Section

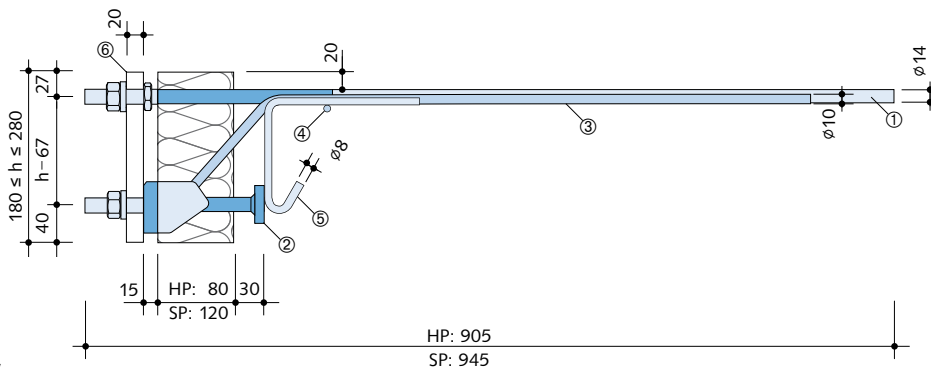

- ① Tension rods
- ② Pressure bearing
- ③ Shear load bar
- ④ Constructive installation rebar
- ⑤ Stirrup
- ⑥ Installation aid

Plan view

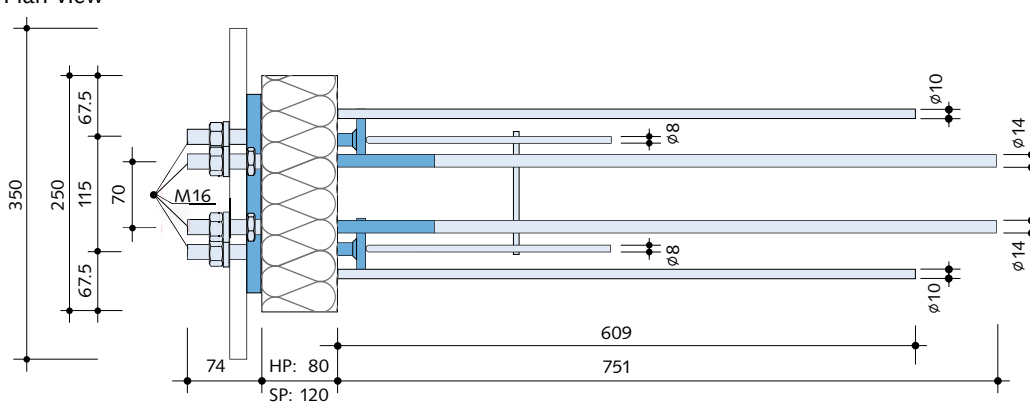

Dimensions in [mm]

HALFEN HIT STEEL TO CONCRETE CONNECTOR HIT-HP SMV, HIT-SP SMV

On-site connecting reinforcement

Section - On-site cast concrete

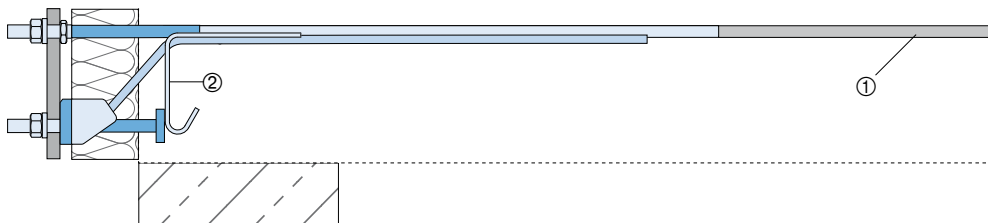

Section - Semi-precast slab

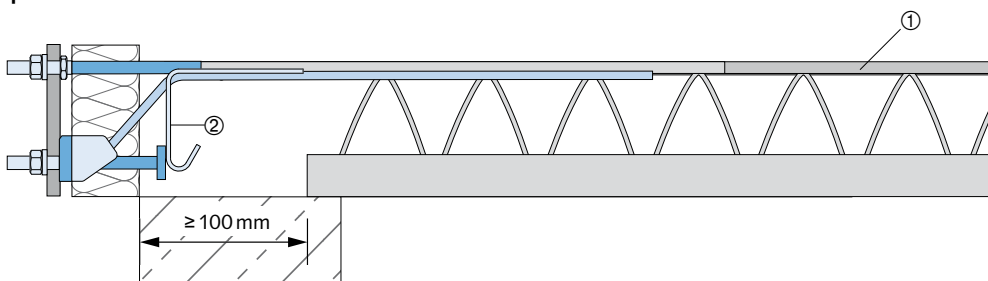

Plan view - On-site cast concrete

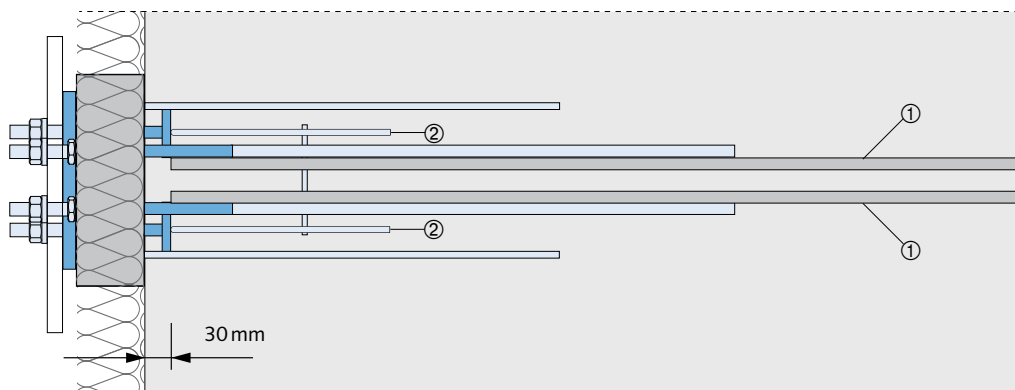

Position ①: $\geq 2\phi 14$; The bar lengths are defined by the tension bar overlap as specified in the structural design plans
Position ②: $2\phi 8$; included in the element

Figures: Overlap with the on-site connecting reinforcement



On-site reinforcement according to the structural engineer's specifications.



Constructive reinforcement for the free slab edge in accordance with EN 1992-1-1, horizontal min. 1 $\phi 8$ mm close to the anchor heads

HALFEN HIT STEEL TO CONCRETE CONNECTOR

HIT-HP SMV, HIT-SP SMV

Deformation

For the HIT-HP/SP SDV elements, the torsional deformations resulting from elastic girder deformation in the insulation/load inducement joint area α_M are assumed due to a standard effective moment $M_{Ed} = 1 \text{ kNm}$.

The required camber to compensate for elastic deformations of the connected steel structure can be approximated as follows:

$$\ddot{u} = \alpha_M \cdot l_k \cdot M_{Ed}$$

- with \ddot{u} = Camber [mm]
 α_M = Torque resulting from $M_{Ed} = 1 \text{ kNm}$;
 Table values in [%/kNm]
 l_k = Span distance of cantilever [m]
 M_{Ed} = Design value of the effective moment [kNm]
 at serviceability limit state (SLS)

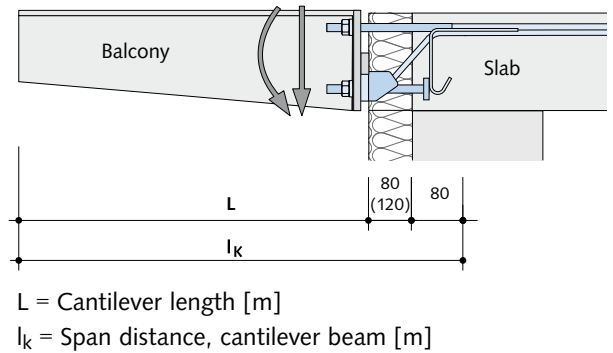

Other deformation factors resulting from deformation of the connected steel structure must be considered by the structural engineer when determining the overall camber. The α_M values [%/kNm] in the following table are in accordance with approval no. Z-15.7-336.

HIT-HP SMV		
α_M [%/kNm] for element height h [mm]	HP SDV-2M16-0208	HP SDV-2M16-0210
180	0.604	0.604
200	0.436	0.436
220	0.330	0.330
240	0.258	0.258
260	0.207	0.207
280	0.170	0.170

HIT-SP SMV		
α_M [%/kNm] for element height h [mm]	SP SMV-2M16-0208	SP SMV-2M16-0210
180	0.722	0.722
200	0.521	0.521
220	0.394	0.394
240	0.308	0.308
260	0.248	0.248
280	0.203	0.203

HALFEN HIT STEEL TO CONCRETE CONNECTOR HIT-HP SMV, HIT-SP SMV

Torsion spring stiffnesses

HIT-HP SMV	
Torsion spring C [kNm/rad] for element height h [mm]	HP SMV-2M16-0208 HP SMV-2M16-0210
180	1750
200	2424
220	3207
240	4101
260	5104
280	6216

HIT-SP SMV	
Torsion spring C [kNm/rad] for element height h [mm]	SP SMV-2M16-0208 SP SMV-2M16-0210
180	1470
200	2037
220	2695
240	3446
260	4289
280	5224

HALFEN HIT STEEL TO CONCRETE CONNECTOR HIT-HP SMV, HIT-SP SMV

Axial spacing

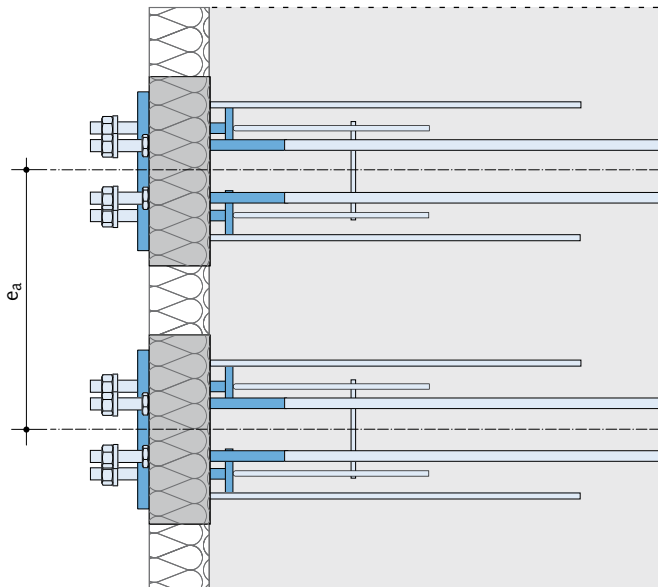

HIT Type	Axial spacing $e_a \geq$ [mm]
HIT-HP SMV-2M16-0208	295
HIT-HP SMV-2M16-0210	295
HIT-SP SMV-2M16-0208	295
HIT-SP SMV-2M16-0210	295

Edge distance

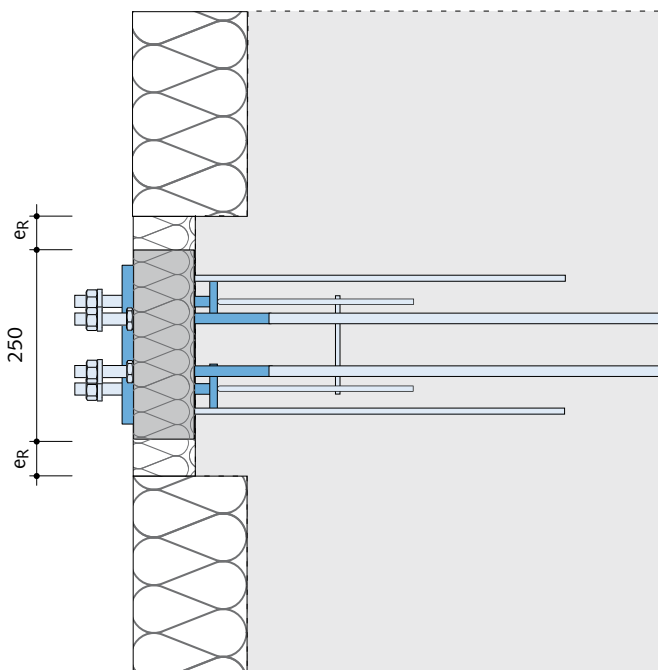

HIT Type	Edge distance e_R [mm]
HIT-HP SMV-2M16-0208	22.5
HIT-HP SMV-2M16-0210	22.5
HIT-SP SMV-2M16-0208	22.5
HIT-SP SMV-2M16-0210	22.5

HALFEN HIT STEEL TO CONCRETE CONNECTOR HIT-HP SMV, HIT-SP SMV

Distance from an outer corner

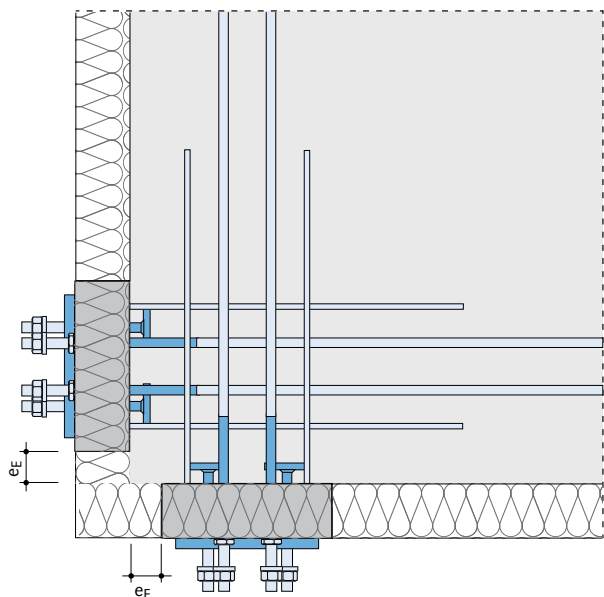

HIT Type	Axial spacing e_E [mm]
HIT-HP SMV-2M16-0208	22.5
HIT-HP SMV-2M16-0210	22.5
HIT-SP SMV-2M16-0208	22.5
HIT-SP SMV-2M16-0210	22.5

Height offset for an outer corner

To install the HIT-SMV elements at an external corner, it is necessary to offset the installation height of the elements. The required height offset is achieved using 20 mm insulation strips (not included).

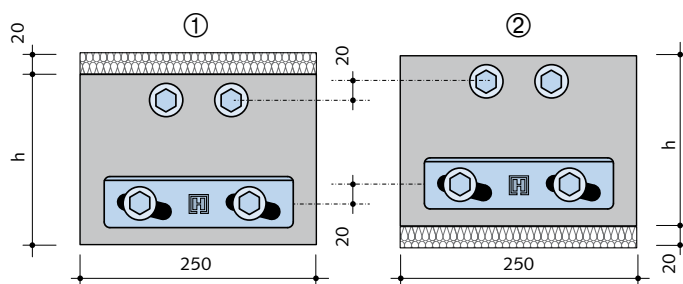
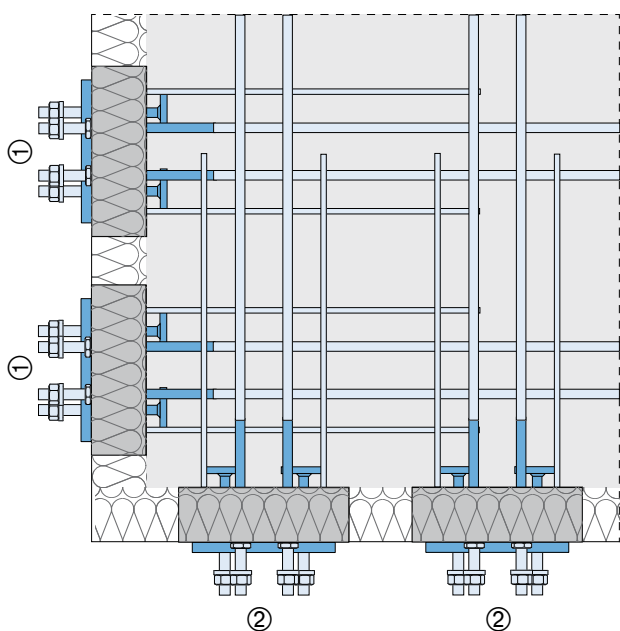

HALFEN HIT STEEL TO CONCRETE CONNECTOR HIT-HP SMV, HIT-SP SMV

Installation in concrete

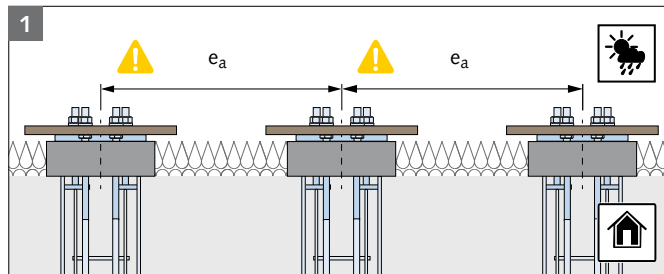

- 1 Installing the bottom reinforcement layer (example, mesh reinforcement).**
Installing the HIT-Element from above.

! Install the HIT Element with increased accuracy for post-installed steel elements!

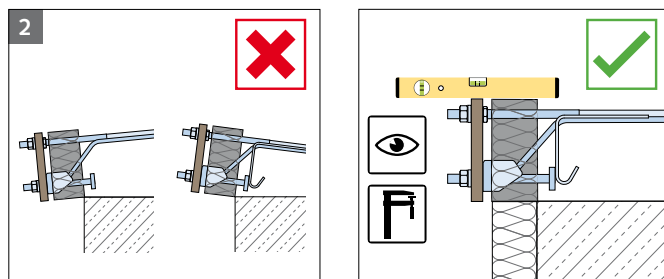

- 2 Accurate installation**

! Ensure installation is exactly horizontal and vertical!

! Ensure the formwork is installed at the correct height!

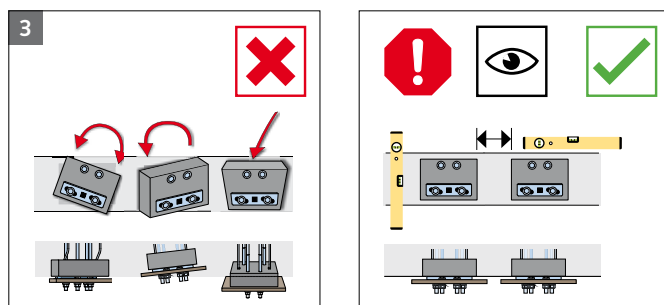

- 3 Checking horizontal and vertical alignment**

The included (wood) installation aids are used to precisely align the elements; the overhanging edges can be used to fix to the on-site formwork as required.

Alternative: Make installation aids on-site (for example, in wood or U-profiles). Use the supplied installation aids or alternatively the our drilling templates to transfer the drill hole sizes and element distances to the on-site made installation aids.

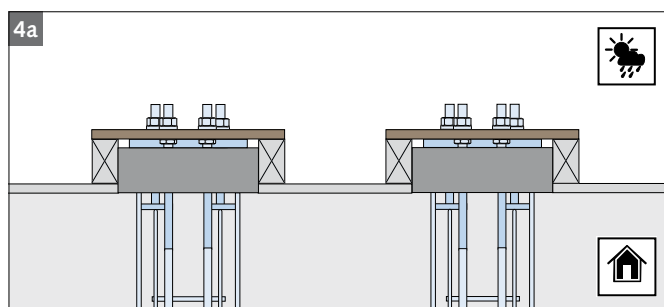

- 4 Installing the formwork**

- a** Concreting directly against the formwork

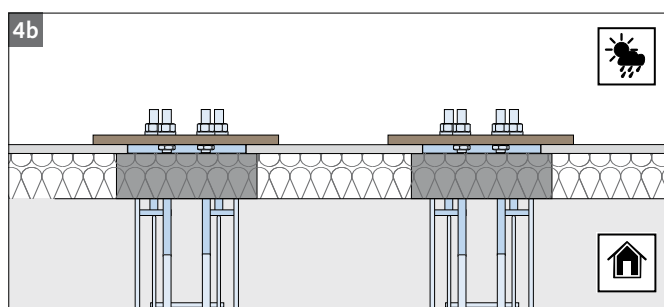

- b** Concreting directly against the insulation

i A free drilling template (.pdf file) is available at:
 ▶ www.halfen.com ▶ Product Ranges ▶ Construction
 ▶ Reinforcement systems ▶ HIT Steel to Concrete Connector
 ▶ Product Information ▶ Installation Instructions

HALFEN HIT STEEL TO CONCRETE CONNECTOR HIT-HP SMV, HIT-SP SMV

Installation in concrete

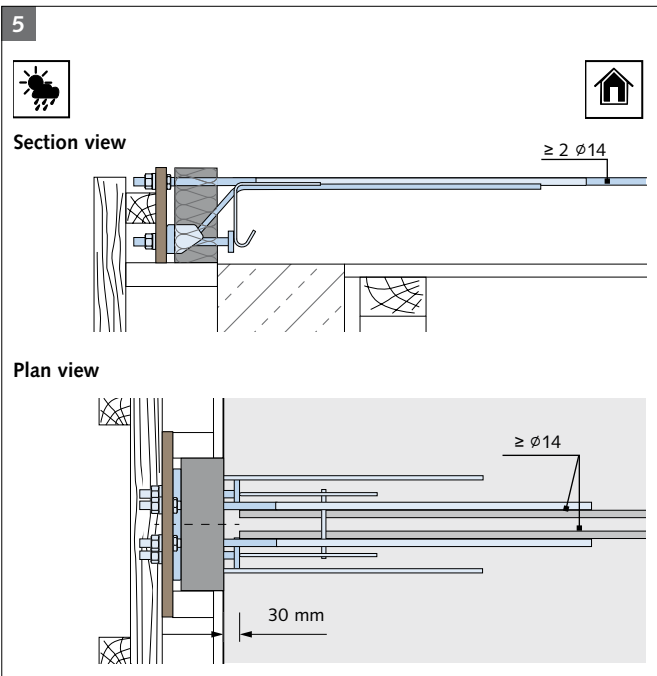

5 Installing the on-site reinforcement

! On-site reinforcement must be placed as specified by the structural engineer.

i Constructive reinforcement for the free slab edge in accordance with EN 1992-1-1, horizontal, min. 1 $\varnothing 8$ mm, close to the anchor heads

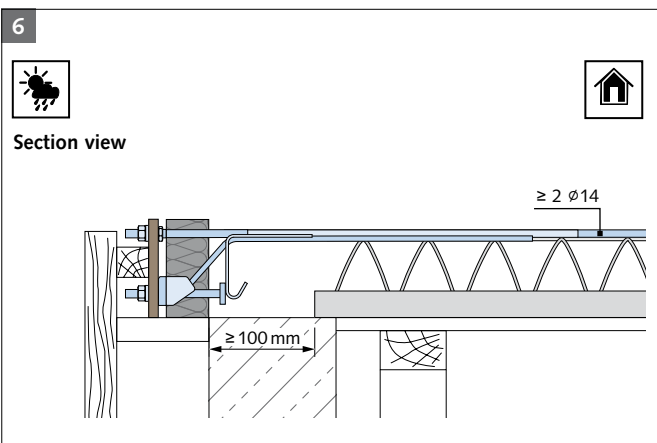

6 Installing the on-site reinforcement for semi-precast elements

! On-site reinforcement must be placed as specified by the structural engineer.

i Constructive reinforcement for the free slab edge in accordance with EN 1992-1-1, horizontal, min. 1 $\varnothing 8$ mm, close to the anchor heads

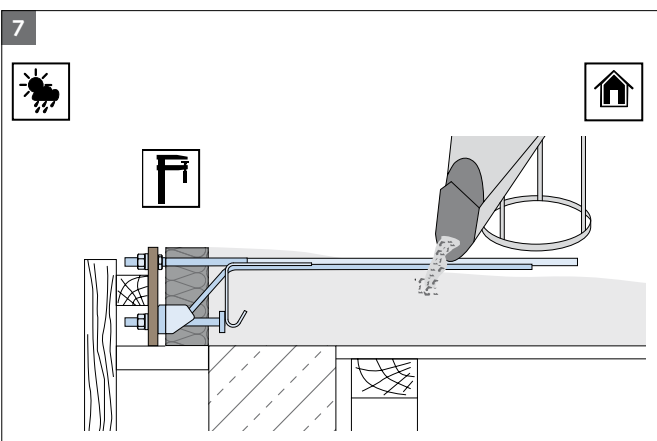

7 Pouring the concrete

! To ensure the HIT units are not displaced, ensure the concrete is poured and compacted evenly.

HALFEN HIT STEEL TO CONCRETE CONNECTOR HIT-HP SZV, HIT-SP SZV

3

- › Element for connecting supported steel constructions to reinforced concrete components
- › Transfer of positive shear loads

TYPE TESTED

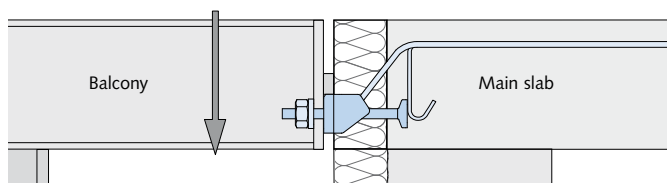
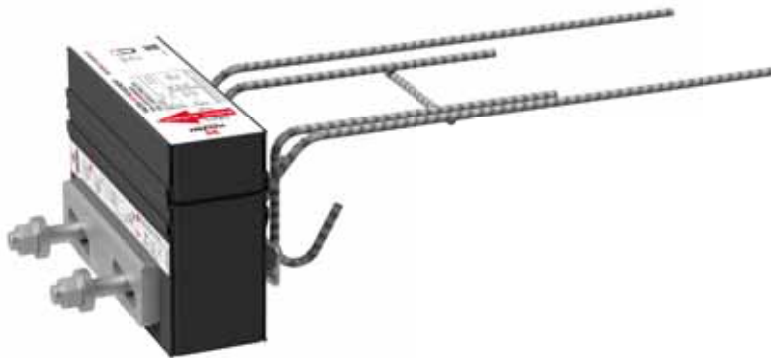

- HIT-HP SZV** - High Performance with 80 mm insulation
HIT-SP SZV - Superior Performance with 120 mm insulation

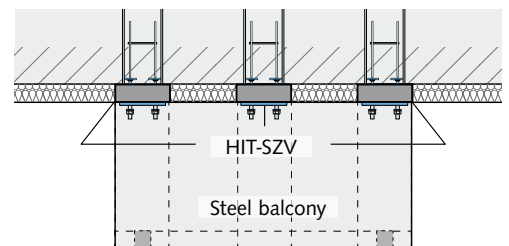

Application: Simply supported balcony slabs on columns

Contents	Type	Page
Load capacity range	HIT-HP SZV, HIT-SP SZV	44
Load capacity values	HIT-HP SZV, HIT-SP SZV	45
Product description	HIT-HP SZV, HIT-SP SZV	46
On-site connecting reinforcement	HIT-HP SZV, HIT-SP SZV	47
Axial spacing	HIT-HP SZV, HIT-SP SZV	48
Installation instructions	HIT-HP SZV, HIT-SP SZV	50

HALFEN HIT STEEL TO CONCRETE CONNECTOR HIT-HP SZV, HIT-SP SZV

Load capacity range

Combinations of three shear load capacities are available. Anchor headed compression elements are used in the concrete slab. Following combinations of shear load bars are possible for insulation thicknesses of HIT-HP 80mm and HIT-SP 120mm.

Element width B = 25 cm

Number and diameter of the connection bolts, balcony side	Number and diameter of the shear load bars		
	2 ϕ 8	2 ϕ 10	2 ϕ 12
2M16	●	●	●

See the following pages for load capacity values for selected elements. ● = HP and SP

Basic types - Ordering example

Ordering example

HIT-HP	SZV	- 0208	- 18
HIT-SP	SZV	- 0212	- 28
↓	↓	↓	↓
①	②	③	④

Type designation

- ① Product group
- ② Joint spacing 80 mm (HP) or 120 mm (SP)
- ③ Connection type
- ④ Shear load range
- ⑤ Element height [cm]



CUSTOM SOLUTIONS

HALFEN HIT Insulated connections

Our technical support team is available if a custom solution is required for your project.

Contact details: → see back cover of catalogue

Technical data

Element description HIT-HP/HIT-SP	Possible element height h [mm]	Balcony side	Main slab side			min. concrete cover slab side [mm]	
		Thread	Compression bars	Shear load bars [mm]	Stirrups [mm]	$C_{v,top}$	$C_{v,bottom}$
SZV-0208	180-280	2M16	Anchor head	2 ϕ 8	2 ϕ 8	≥ 20	33
SZV-0210		2M16	Anchor head	2 ϕ 10	2 ϕ 8	≥ 20	33
SZV-0212		2M16	Anchor head	2 ϕ 12	2 ϕ 8	≥ 20	33

HALFEN HIT STEEL TO CONCRETE CONNECTOR HIT-HP SZV, HIT-SP SZV

Resistance at ultimate load capacity



Shear load capacity

Concrete strength: C20/25 \geq C25/30



HIT-HP SZV	Section A-A $V_{Rd,A}$ [kN]					
Design values	HP SZV-0208		HP SZV-0210		HP SZV-0212	
Element height 180–280 mm	33.5	33.5	52.3	52.3	75.3	75.3

Load bearing capacity values for concrete strength C30/37 can be found in the type tests at www.halfen.com or on request. See back cover for contact information.



Shear load capacity

Concrete strength: C20/25 \geq C25/30



HIT-SP SZV	Section A-A $V_{Rd,A}$ [kN]					
Design values	SP SZV-0208		SP SZV-0210		SP SZV-0212	
Element height 180–280 mm	28.1	28.1	43.9	43.9	56.8	56.8

Load bearing capacity values for concrete strength C30/37 can be found in the type tests at www.halfen.com or on request. See back cover for contact information.

HALFEN HIT STEEL TO CONCRETE CONNECTOR HIT-HP SZV, HIT-SP SZV

Product description

HIT-HP/SP SZV-0208 with installation aid

Section

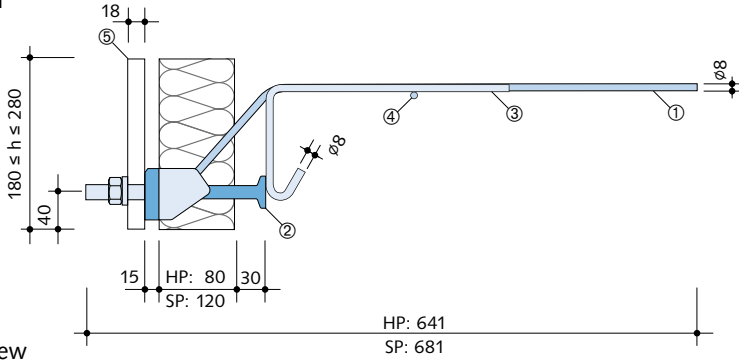

- ① Shear load bars
- ② Pressure bearing
- ③ Stirrups
- ④ Constructive installation rebar
- ⑤ Installation aid

Plan view

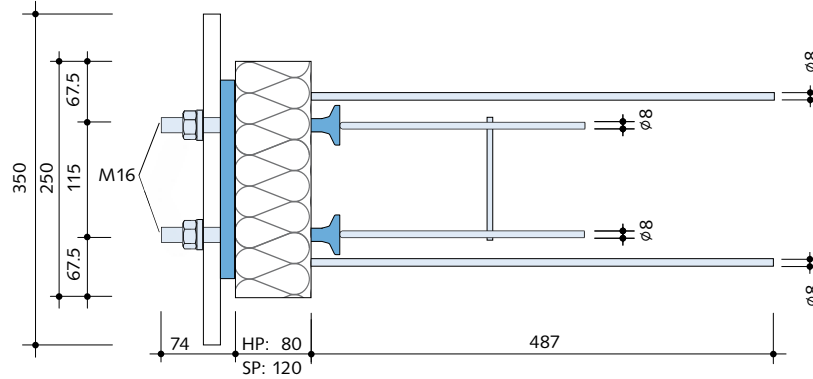

Dimensions in [mm]

HIT-HP/SP SZV-0210 and HIT-HP/SP SZV-0212 with installation aid

Section

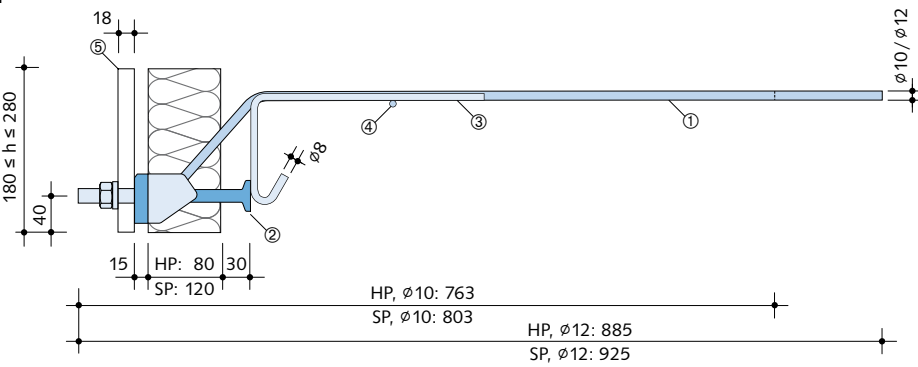

- ① Shear load bars
- ② Pressure bearing
- ③ Stirrups
- ④ Constructive installation rebar
- ⑤ Installation aid

Plan view

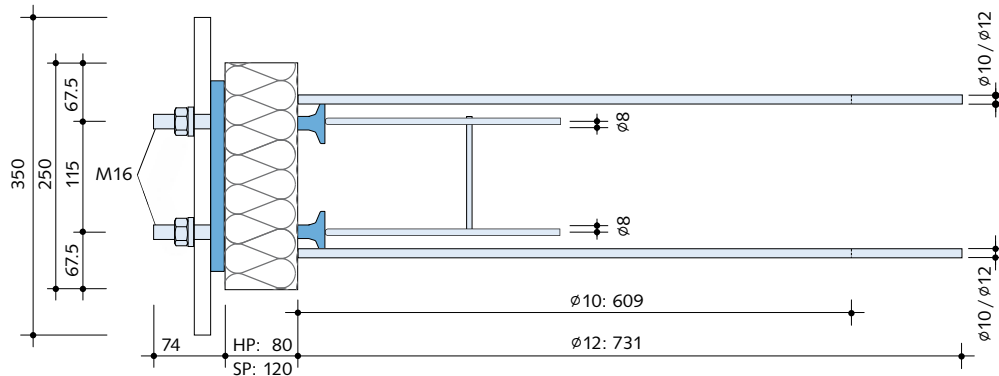

Dimensions in [mm]

HALFEN HIT STEEL TO CONCRETE CONNECTOR HIT-HP SZV, HIT-SP SZV

On-site reinforcement

Section – On-site cast concrete

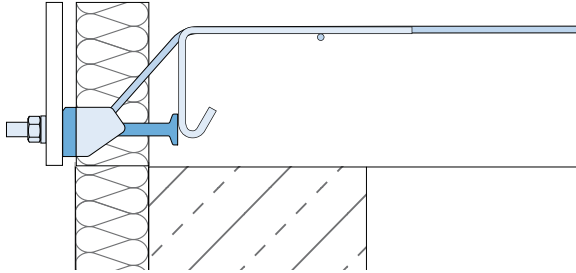

- i** Constructive reinforcement for the free slab edge in accordance with EN 1992-1-1, horizontal, min. 1 \varnothing 8 mm, close to the anchor heads

Section – semi-precast element

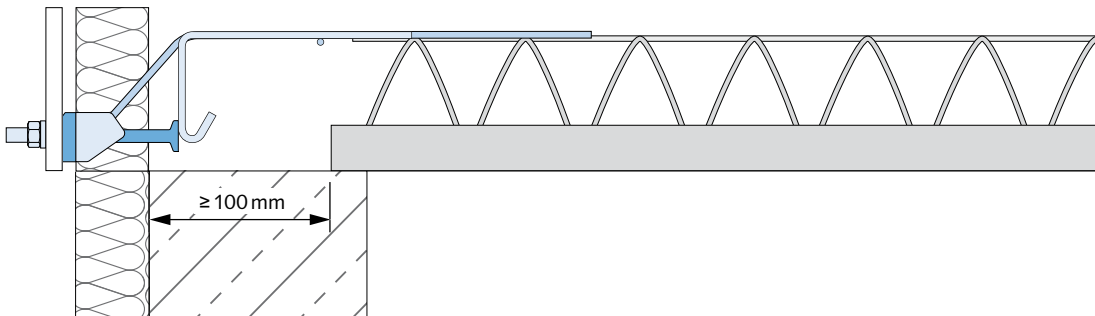

- i** On-site reinforcement according to the structural engineer's specifications.

Plan view – On-site cast concrete



HALFEN HIT STEEL TO CONCRETE CONNECTOR HIT-HP SZV, HIT-SP SZV

Axial spacing

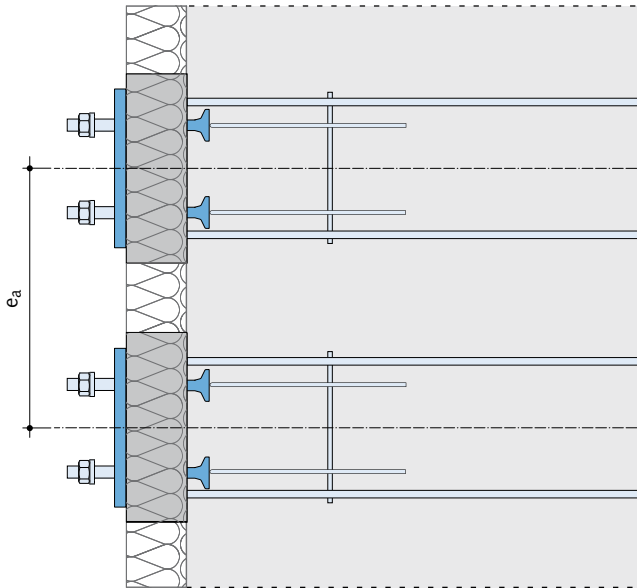

HIT Type	Axial spacing e_a [mm]
HIT-HP SZV-0208	250
HIT-HP SZV-0210	
HIT-HP SZV-0212	
HIT-SP SZV-0208	
HIT-SP SZV-0210	
HIT-SP SZV-0212	

Edge distance

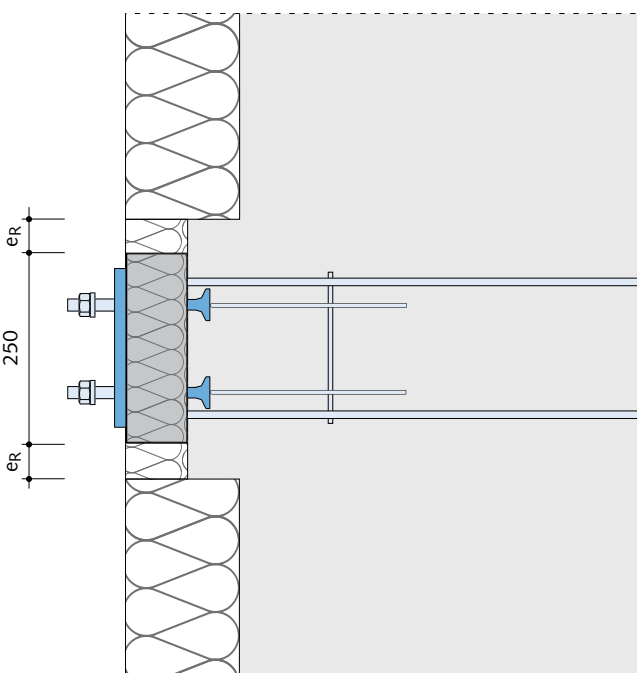

HIT Type	Distance e_R [mm]
HIT-HP SZV-0208	11
HIT-HP SZV-0210	22
HIT-HP SZV-0212	33
HIT-SP SZV-0208	11
HIT-SP SZV-0210	22
HIT-SP SZV-0212	33

HALFEN HIT STEEL TO CONCRETE CONNECTOR HIT-HP SZV, HIT-SP SZV

Distance from a outer corner

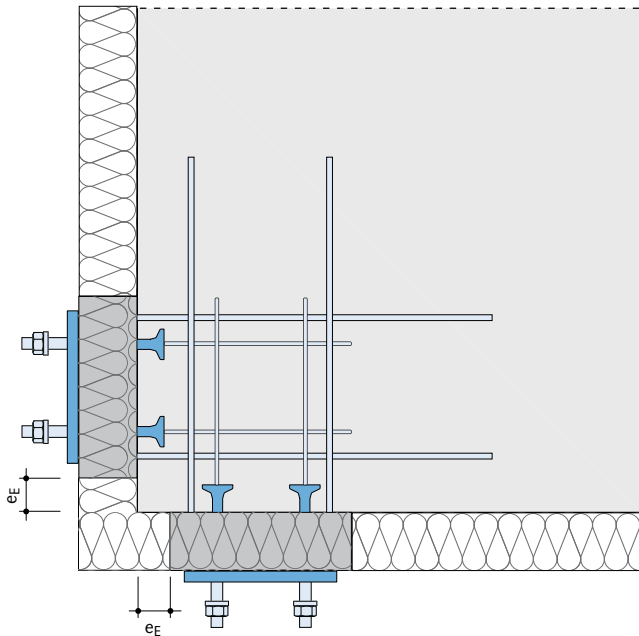

HIT Type	Distance $e_E \geq$ [mm]
HIT-HP SZV-0208	11
HIT-HP SZV-0210	22
HIT-HP SZV-0212	33
HIT-SP SZV-0208	11
HIT-SP SZV-0210	22
HIT-SP SZV-0212	33

Height-offset for an outer corner

To install the HIT-SZV elements at an external corner, it is necessary to offset the installation height of the elements. The required height offset is achieved using 20 mm insulation strips (not included).

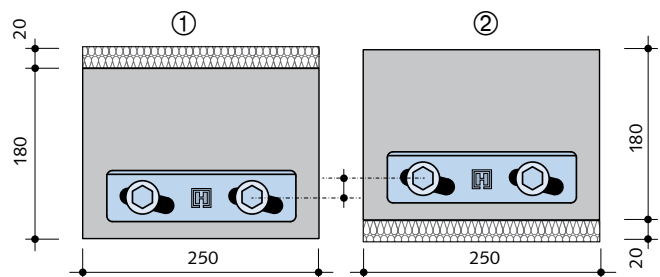
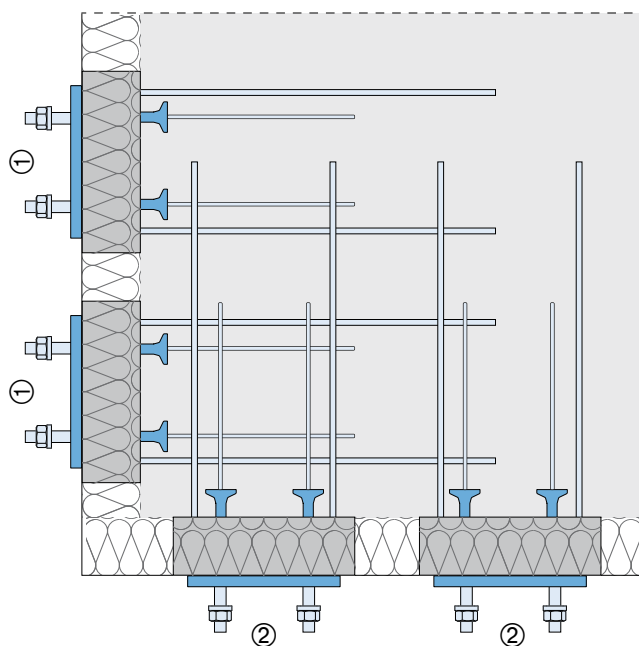

HALFEN HIT STEEL TO CONCRETE CONNECTOR HIT-HP SZV, HIT-SP SZV

Installation in concrete

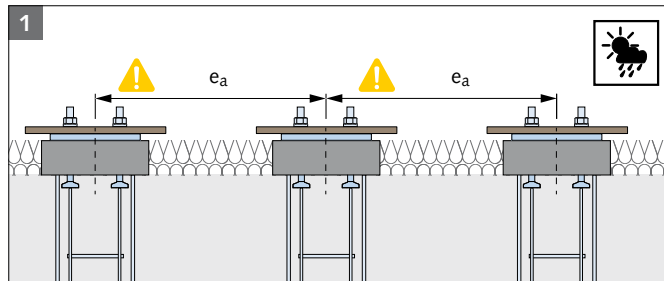

- 1** Installing the bottom reinforcement layer (example, mesh reinforcement). Installing the HIT-Element from above.



Install the HIT Element with increased accuracy if the steel construction is to be post-installed!

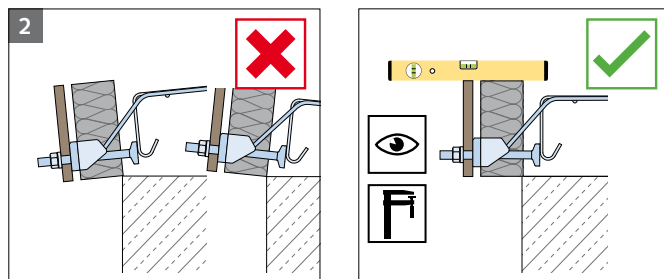

- 2** Accurate installation



Ensure installation is exactly horizontal and vertical!



Ensure the formwork is installed at the correct height!

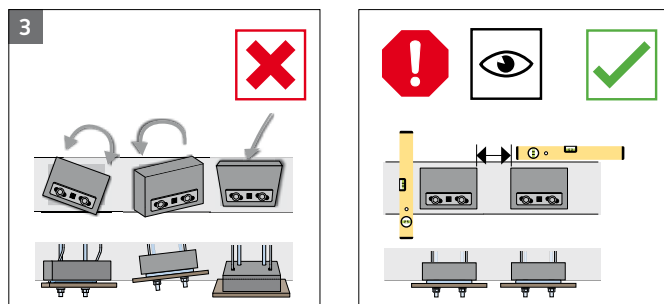

- 3** Checking horizontal and vertical alignment

The included (wood) installation aids are used to precisely align the elements; the overhanging edges can be used to fix to the on-site formwork as required.

Alternative: Make installation aids on-site (for example, in wood or U-profiles). Use the supplied installation aids or alternatively the HALFEN drilling templates to transfer the drill hole sizes and element distances to the on-site made installation aids.

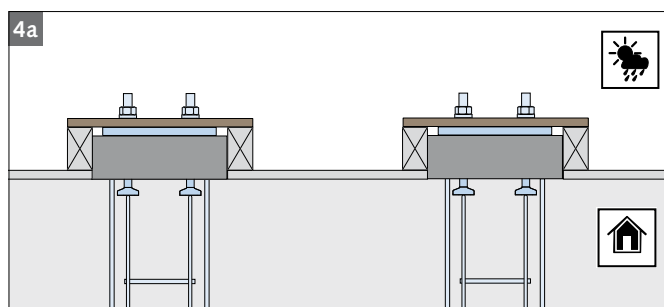

- 4** Installing the formwork

- a** Concreting directly against the formwork

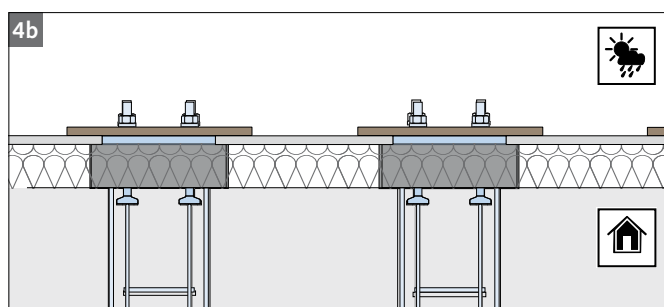

- b** Concreting directly against the insulation



A free drilling template (.pdf file) is available at:

- ▶ www.halfen.com ▶ Product Ranges ▶ Construction
- ▶ Reinforcement systems ▶ HIT Steel to Concrete Connector
- ▶ Product Information ▶ Installation Instructions

HALFEN HIT STEEL TO CONCRETE CONNECTOR HIT-HP SZV, HIT-SP SZV

Installation in concrete

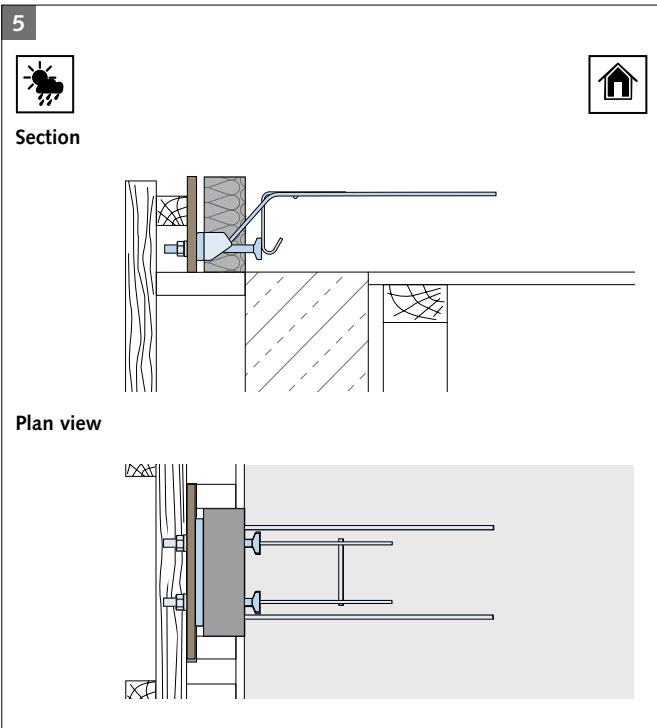

5 Installation of the on-site reinforcement



On-site reinforcement according to the structural engineer's specifications.



Constructive reinforcement for the free slab edge in accordance with EN 1992-1-1, horizontal, min. 1 \varnothing 8 mm, close to the anchor heads.

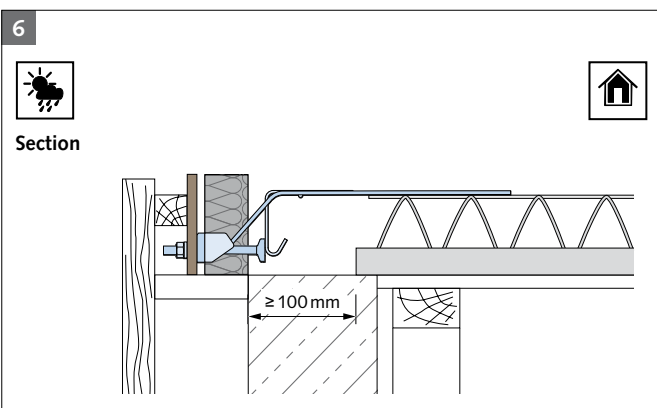

6 Installing the on-site reinforcement for a semi-precast slab



On-site reinforcement according to the structural engineer's specifications.



Constructive reinforcement for the free slab edge in accordance with EN 1992-1-1, horizontal, min. 1 \varnothing 8 mm, close to the anchor heads.

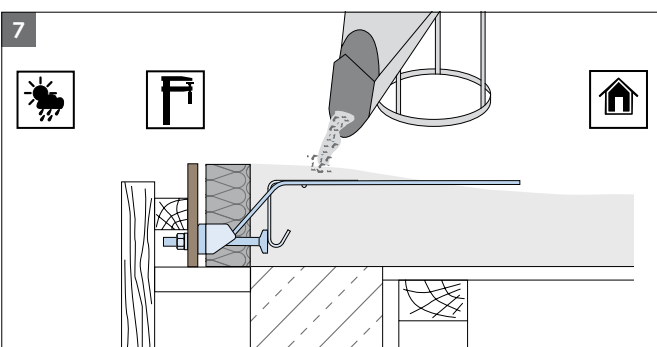

7 Pouring the concrete



To ensure the HIT elements are not displaced, ensure the concrete is poured and compacted evenly.

HALFEN HIT STEEL TO CONCRETE CONNECTOR

Design and installation of the connected elements

4 > Design and installation of connected elements



Contents

	Page
On-site facing plate with notch	53
Connecting support elements	55
Installation and height adjustment	56
Installation of structural steel elements	57
Expansion joint spacings	58

HALFEN HIT STEEL TO CONCRETE CONNECTOR

Design and installation of the connected elements

On-site facing plate with notch

On-site facing plates with notch are required to fasten and support connected elements to the HIT Insulated connection. The facing plates thickness t_s is specified by the structural

engineer keeping within the stipulated limits. The maximum thickness $t_{s,max}$ of the facing plates depends on the available clamping length of the HIT element.

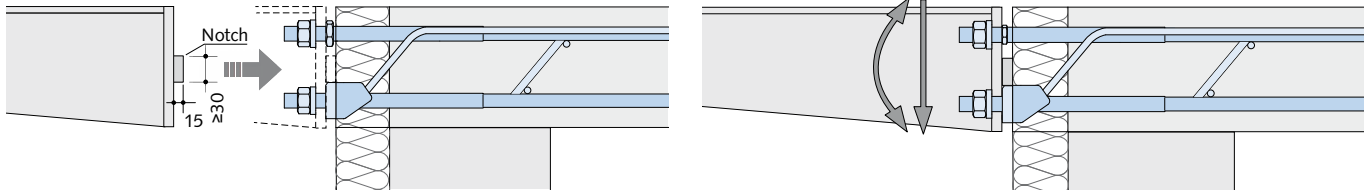

Dimensions in [mm]

Connection thread	Clamp length	Tightening torques
M16	≤30mm	$M_R = 100\text{Nm}$
M22	≤40mm	$M_R = 200\text{Nm}$

On-site welded notch

Shear loads are transferred from the on-site facing plate through an on-site welded notch.

Specifications for the notch:

- $h_{min.notch} = 30\text{mm}$
- $b_{min.notch} = 50\text{mm}$
- $t_{notch} = 15\text{mm}$
- Steel grade, minimum strength $f_{yk} = 235\text{N/mm}^2$
- Weld seam $a_{w,min} = 4\text{mm}$, closed weld seam

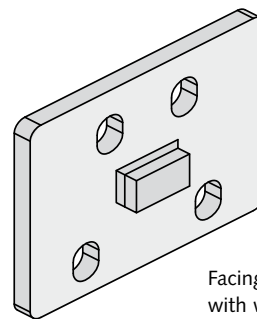

Facing plate with welded notch

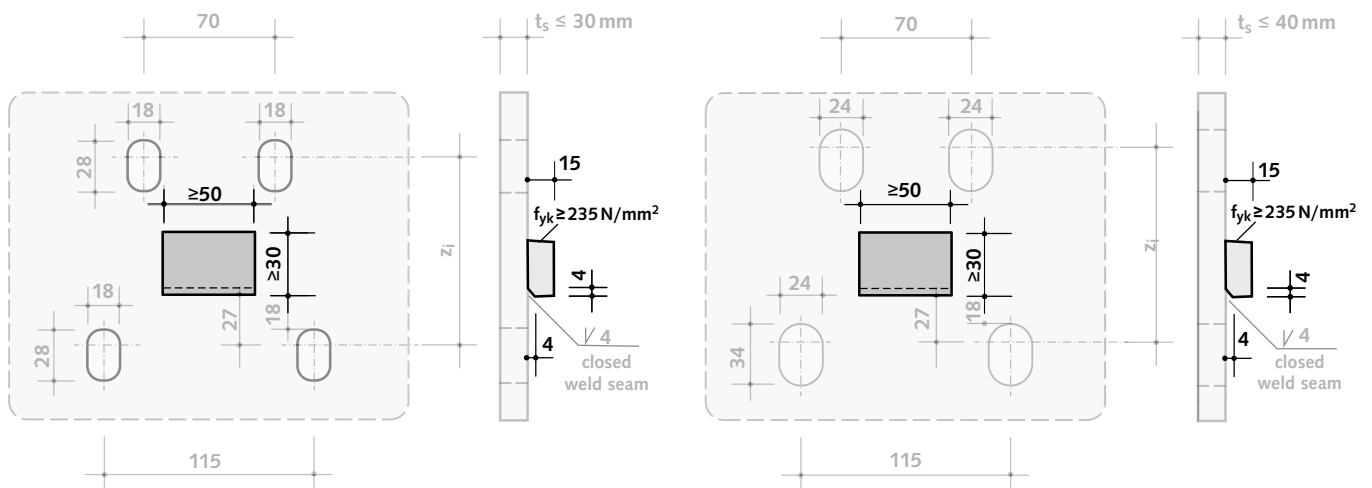

HALFEN HIT STEEL TO CONCRETE CONNECTOR

Design and installation of the connected elements

On-site facing plate with notch

Hole layout for HIT-SDV and HIT-SMV with M16 thread
(HIT-HP/SP SDV-2M16, HIT-HP/SP SMV-2M16)

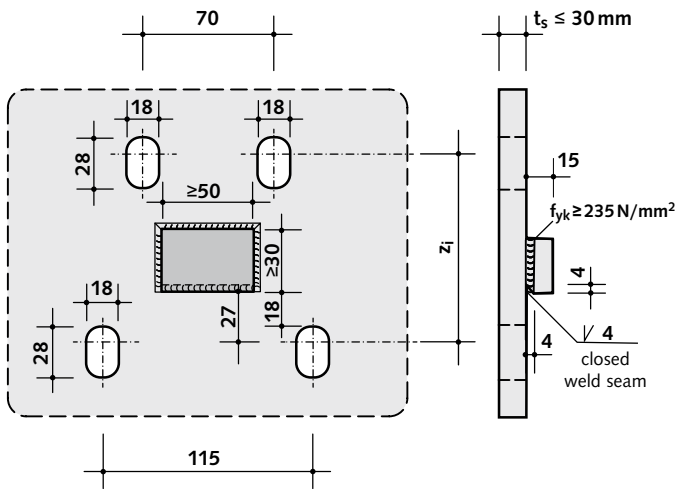

The holes layout in the facing plate depends on the bar diameter and the height of the HIT element.

The slots allow the plate to move vertically by up to 10 mm. The facing plate dimensions are specified by the structural engineer, the distances between the slots and the outer edge of the facing plate must be verified.

The facing plate with its central notch is not designed for lifting-loads. The actual dimensions of the embedded HIT elements must be checked before manufacturing the facing plate to ensure a precise fit. On-site corrosion protection is only applied after all welding work has been finished.

Hole layout for HIT-SZV with M16 thread
(HIT-HP/SP SZV-2M16)

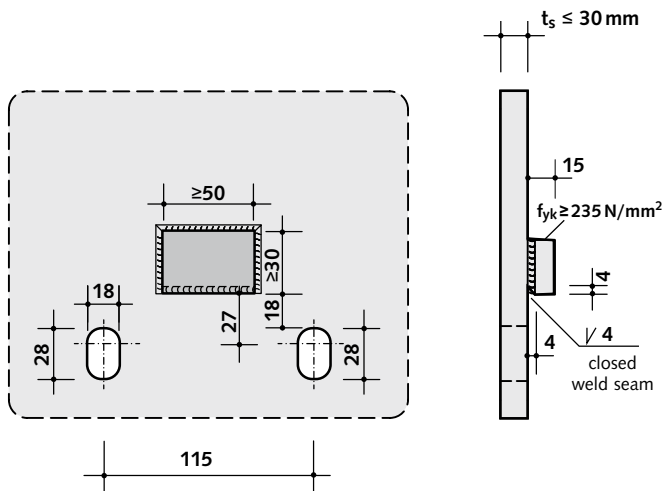

Hole layout for HIT-SMV with M22 thread
(HIT-HP/SP SDV-2M22, HIT-HP/SP SMV-2M22)

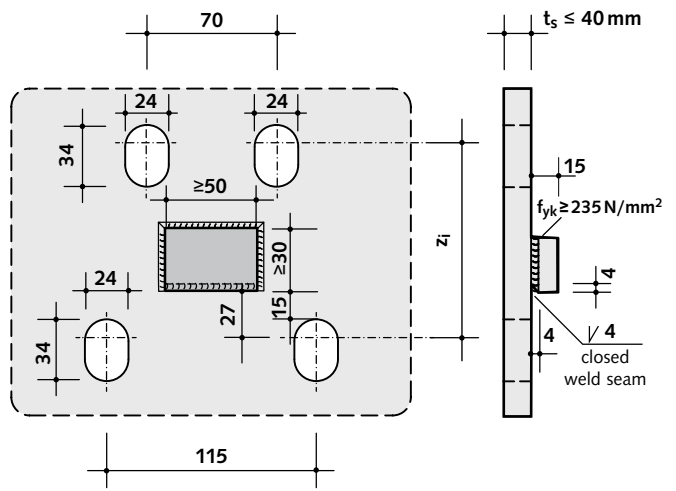

HIT-HP/SP	Connecting thread M16					
HIT Height h [mm]	180	200	220	240	260	280
z _i = hole spacing [mm]	113	133	153	173	193	213

HIT-HP/SP	Connecting thread M22					
HIT Height h [mm]	180	200	220	240	260	280
z _i = hole spacing [mm]	108	128	148	168	188	208

HALFEN HIT STEEL TO CONCRETE CONNECTOR

Design and installation of the connected elements

Connected steel components

The shape and dimensions of the connected steel components are specified by the structural engineer. Steel components; a minimum distance h_{LF} must be observed in the facing plate from the top flange to the upper-edge of the upper slotted

hole and from the lower-edge of the bottom slotted holes to the bottom flange. The minimum spacing h_{LF} and a height tolerance of 10 mm provide the minimum dimension of the steel profiles.

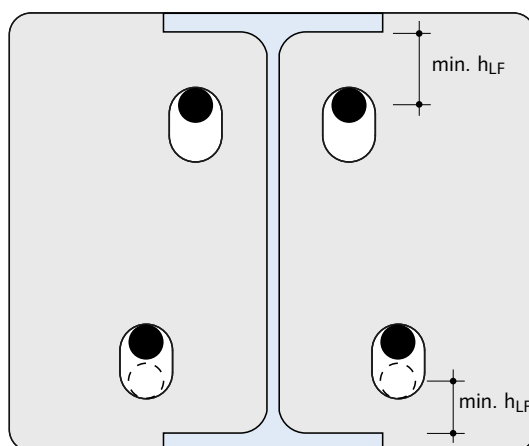

Depending on the connection thread, the following min. steel profile sizes are recommended for the various HIT Element heights:

HIT-HP/SP	min $h_{LF} = 25\text{ mm}$			
SDV-2M16 SMV-2M16	IPE	HEA	HEB	HEM
180	200	220	220	220
200	220	240	240	240
220	240	260	260	260
240	270	280	280	280
260	300	300	300	300
280	300	320	320	320

HIT-HP/SP	min $h_{LF} = 30\text{ mm}$			
SDV-2M22	IPE	HEA	HEB	HEM
180	200	220	220	220
200	220	240	240	240
220	240	260	260	280
240	270	280	280	280
260	300	300	300	300
280	300	320	320	320

HALFEN HIT STEEL TO CONCRETE CONNECTOR

Design and installation of the connected elements

Installation and height adjustment

Check the dimensions and positions of the connection threads (HIT Elements) on-site before attempting to install connected components. Checking the dimensions before manufacture, and before delivery of elements if these were constructed off-site is also recommended.

The facing plate design as in the figure on page 50 provides a vertical tolerance up to 10 mm in both directions.

Height adjustment is achieved using the pre-fitted angled slotted bracket; moving the facing plate horizontally (tap lightly with a hammer) causes a vertical movement of the facing plate. To ensure a tolerance in both directions, a central alignment is recommended; see figure B.



The following should be checked before connecting steel elements to the HIT component:

- › are the sizes and positions of the connection holes as specified?
- › is the notch present on the facing plate?
- › is the size and position of the notch as specified?

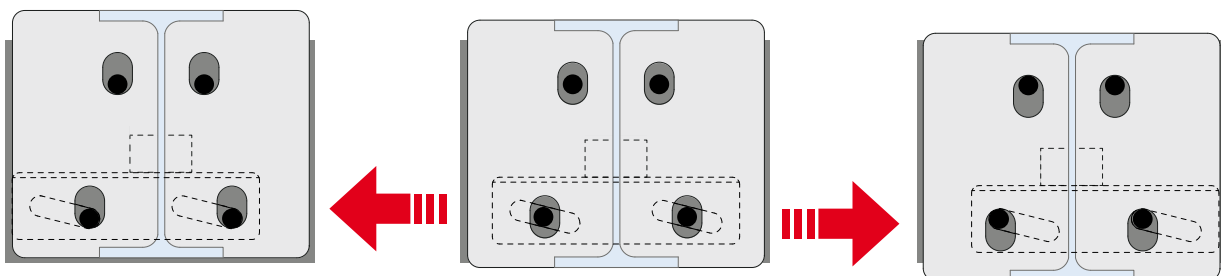

Figure A: Threaded bolt positioned at the bottom of the slot

Figure A: Threaded bolt positioned at the centre of the slot

Figure A: Threaded bolt positioned at the top of the slot



The screw threads may be shortened; a minimum of two turns of the threads must remain visible after fixing any components.

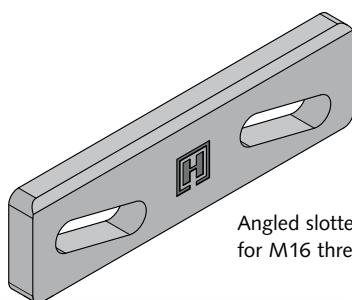

Angled slotted bracket for M16 thread

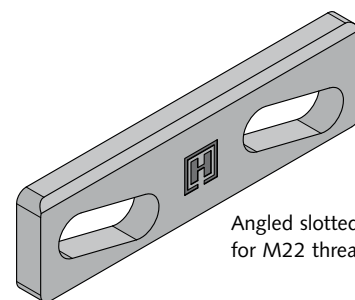

Angled slotted bracket for M22 thread

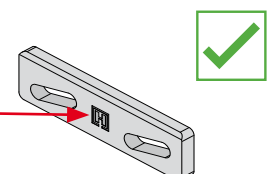
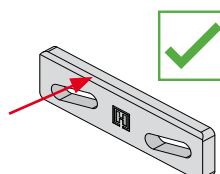

Please observe the information on the label

Correct installation of the angled slotted bracket: bevelled edge at the top, HALFEN logo on the front.

HALFEN HIT STEEL TO CONCRETE CONNECTOR

Design and installation of the connected elements

Installing of steel components

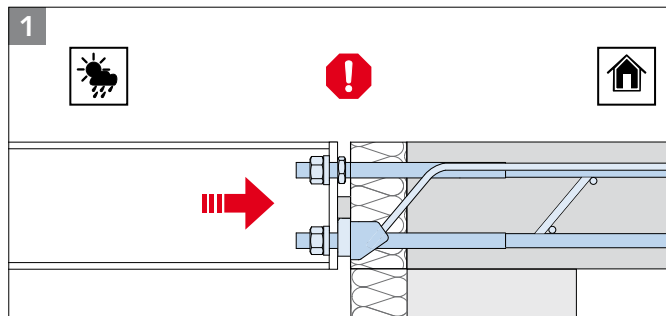

1 Fixing of steel girders

Only use on-site end plates with notch

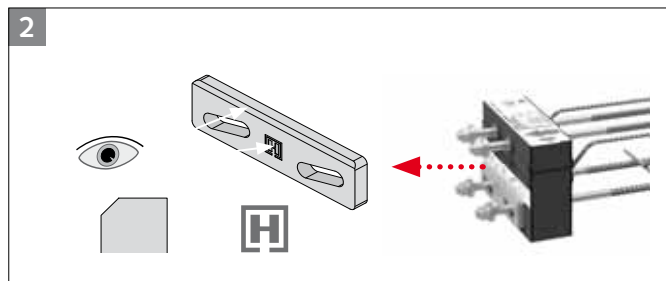
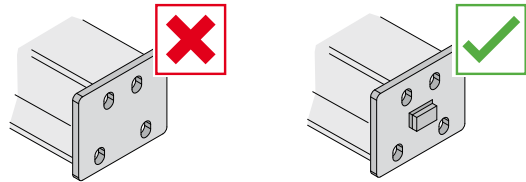

2 Please observe the information on the label

Correct orientation of the angled slotted bracket:
HALFEN logo is visible, bevelled edge at the top.

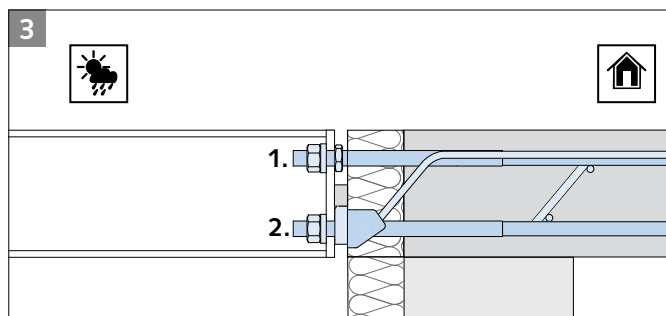

3 Fixing steel components

Attach to the top threads first,
then attach to the bottom threads.

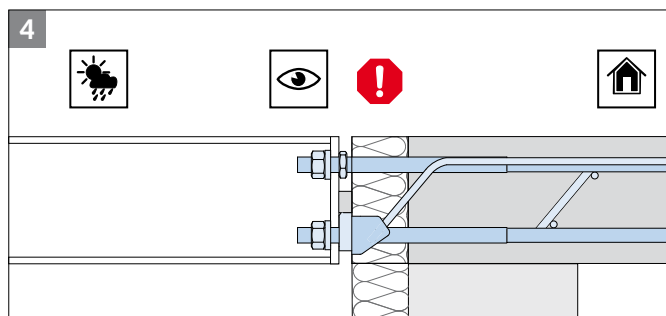

4 Check the steel connection has been installed as planned

Check the gradient is in accordance with the design specifications! Check if the element is horizontally level or if the camber (where planned) is correct.

On-site reinforcement must be placed as specified by the structural engineer.

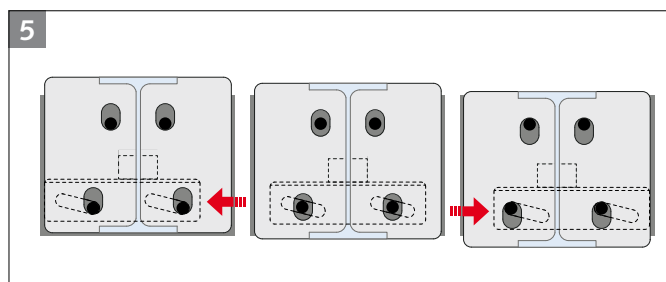

5 Final adjustment, then tighten the nuts

The thread anchors may be shortened; ensure **at least two turns** of the threads remain visible after final installation.

HALFEN HIT STEEL TO CONCRETE CONNECTOR Design and installation of the connected elements

Expansion joint spacings

Calculation of the allowable joint spacing is in accordance with Building Authority Approval no. Z-15.7-336 and is based on a balcony slab firmly fixed to steel supports. In this case, expansion joints must be provided in the exterior component.

A limit of $0.5 s_{\text{joint}}$ per leg also applies for inner corners. s_{joint} refers to outer edge HIT to outer edge HIT. Overhang on the right and left can be included here.

The distance between the expansion joints must not exceed s_{joint} [m] for linear, cantilevered balcony slabs. Balcony designed for external corners, are limited to a maximum expansion joint spacing of $0.5 s_{\text{joint}}$ for each leg.

If constructive measures are taken to allow expansion/contraction between the balcony slab and each steel beam – such as designing slotted holes in the cross beams – then expansion joints are not required.

Tension bar diameter in the insulation [mm]	s_{joint} max. expansion joint spacing [m]	
	HIT-HP (80 mm)	HIT-SP (120 mm)
M16	9.8	16.5
M22	7.9	13.3

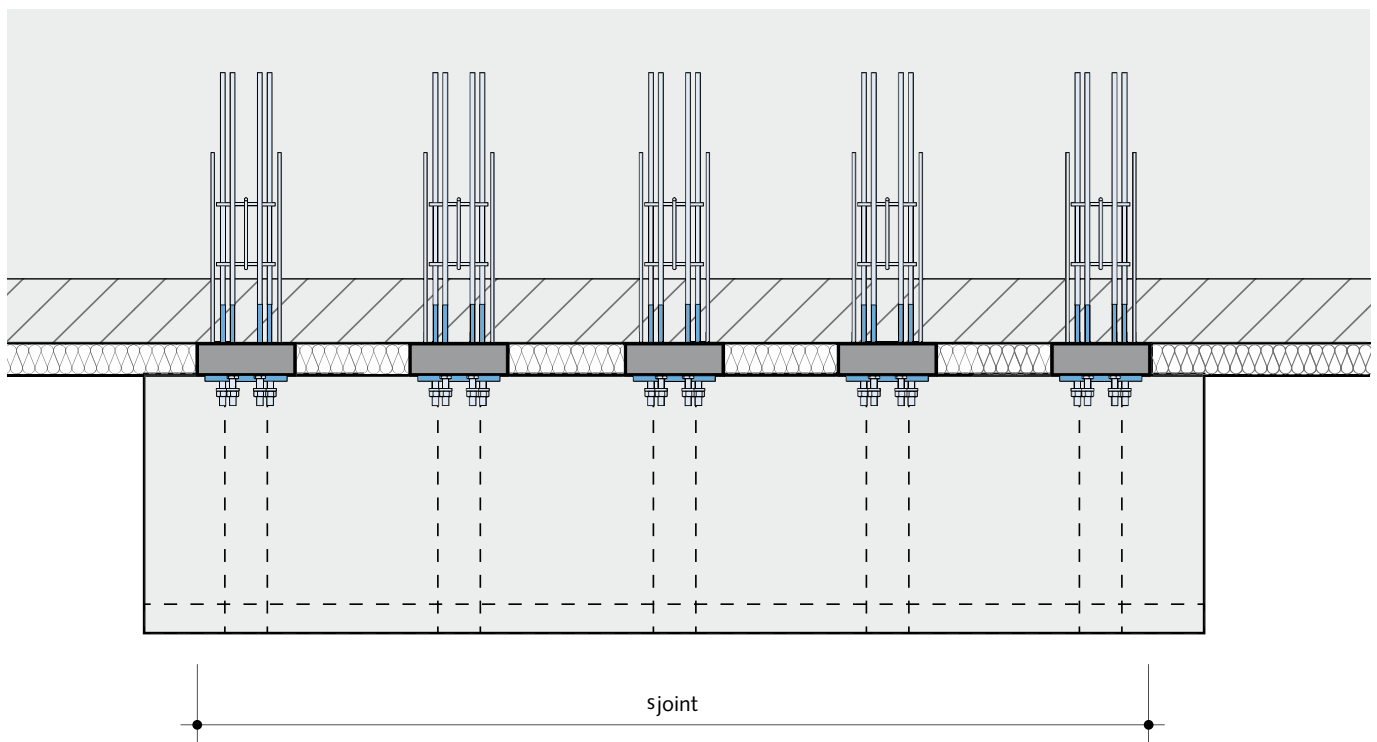

HALFEN HIT STEEL TO CONCRETE CONNECTOR Building physics

5

> Building physics

The illustration of the temperature field in the horizontal section through a ceiling slab, shown here as an isothermal curve, demonstrates the excellent insulating properties of the HIT Steel to concrete connectors. These connectors form effective thermal separation of the exterior balcony compo-

nents. The good insulation stops the temperature sinking below the point of condensation preventing water damage. The efficient, building physics design also prevents cracks forming caused by thermal expansion of the metal balcony components.

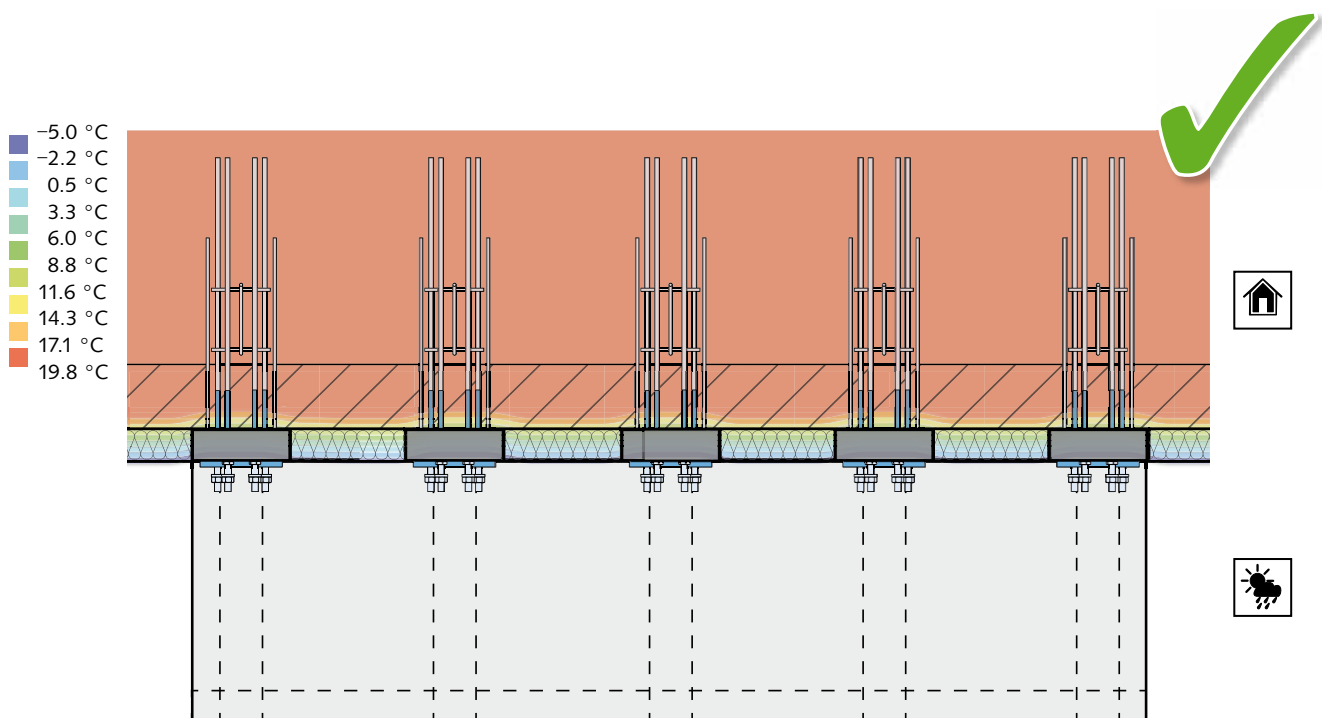

Contents

	Page
Key values for thermal bridgings	60
Key values for thermal bridges according to Building Authority Approval	61
Key values for thermal bridges for HIT-HP and masonry using ETICS	65
Key values for thermal bridges for HIT-SP and masonry using ETICS	66

HALFEN HIT STEEL TO CONCRETE CONNECTOR Building physics

Key values for thermal bridges

Equivalent thermal conductivity λ_{eq}

Composite building elements – including the HIT insulated connection – consist of different building materials with different thermal conductivities.

A detailed analysis of this type of product can be very complex. To simplify the process, a homogeneous, cuboid substitute sample is assumed in the insulation joint, with the same dimensions. An equivalent thermal conductivity λ_{eq} is assigned to the substitute sample so that the total heat transfer of both systems is identical. The definition of the λ_{eq} values is based on meticulous three-dimensional thermal bridge calculations.

Calculation of the equivalent thermal conductivity is defined in Building Authority approval no. Z-15.7-336 issued by the DiBt (German Institute of Building Technology).

The λ_{eq} values cannot be used directly to calculate the primary energy demand of a building. The local thermal transfer coefficient χ can be determined using thermal bridge software, and therefore, the transmission losses can be calculated. In this case the thermal boundary conditions according to EN ISO 6946 and DIN 4108 annex 2 must be observed.

Heat transmission coefficient χ

Local thermal bridges are penetrations in the building envelope that can be referenced to a specific area. The heat loss resulting from these thermal bridges are defined using a local thermal transfer value χ . The χ values are therefore important variables for calculating the energy loss of local thermal bridges. The calculated values for a masonry wall using ETICS* can be found on pages 65ff.

*ETICS External Thermal Insulation Composite System.

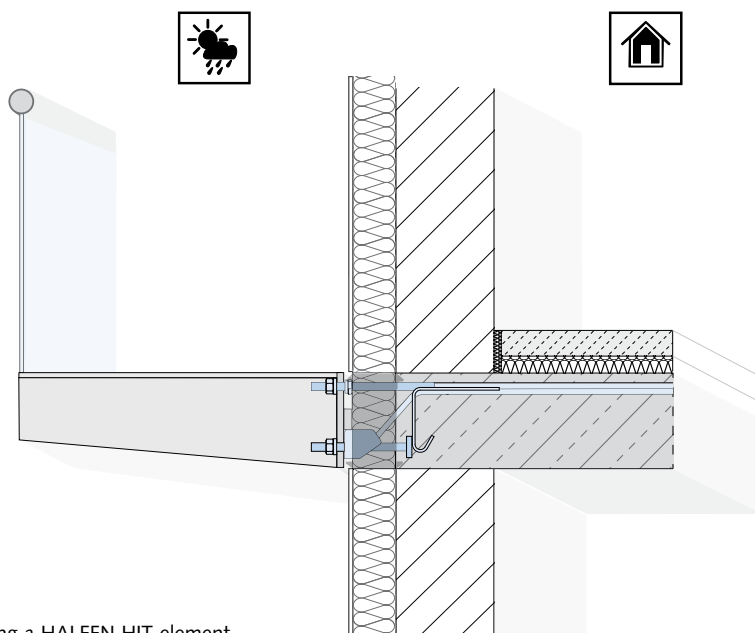

Figure: Cross section showing a HALFEN HIT element, connected to a (interior) concrete slab.

HALFEN HIT STEEL TO CONCRETE CONNECTOR

Building physics

Thermal values according to Building Authority Approval

The thermal characteristic values for equivalent thermal conductivity λ_{eq} and equivalent thermal resistance R_{eq} have been calculated based on Building Authority

approval no. Z-15.7-336, for all HIT Steel to concrete connections with heights from 18 to 28 cm; see the tables on the following pages.

HIT Type	Height [mm]	Insulation thickness [mm]	Equivalent thermal conductivity λ_{eq} [W/(mK)]	Equivalent thermal resistance R_{eq} [m ² K/W]
HIT-HP SDV-2M16-0208				
HIT-HP SDV-2M16-0208-18	180	80	0.314	0.255
HIT-HP SDV-2M16-0208-20	200	80	0.286	0.280
HIT-HP SDV-2M16-0208-22	220	80	0.263	0.304
HIT-HP SDV-2M16-0208-24	240	80	0.244	0.327
HIT-HP SDV-2M16-0208-26	260	80	0.228	0.350
HIT-HP SDV-2M16-0208-28	280	80	0.215	0.373
HIT-HP SDV-2M16-0210				
HIT-HP SDV-2M16-0210-18	180	80	0.333	0.240
HIT-HP SDV-2M16-0210-20	200	80	0.304	0.263
HIT-HP SDV-2M16-0210-22	220	80	0.279	0.286
HIT-HP SDV-2M16-0210-24	240	80	0.259	0.309
HIT-HP SDV-2M16-0210-26	260	80	0.242	0.331
HIT-HP SDV-2M16-0210-28	280	80	0.227	0.352
HIT-HP SDV-2M22-0208				
HIT-HP SDV-2M22-0208-18	180	80	0.531	0.151
HIT-HP SDV-2M22-0208-20	200	80	0.482	0.166
HIT-HP SDV-2M22-0208-22	220	80	0.441	0.181
HIT-HP SDV-2M22-0208-24	240	80	0.407	0.196
HIT-HP SDV-2M22-0208-26	260	80	0.379	0.211
HIT-HP SDV-2M22-0208-28	280	80	0.354	0.226
HIT-HP SDV-2M22-0210				
HIT-HP SDV-2M22-0210-18	180	80	0.551	0.145
HIT-HP SDV-2M22-0210-20	200	80	0.499	0.160
HIT-HP SDV-2M22-0210-22	220	80	0.457	0.175
HIT-HP SDV-2M22-0210-24	240	80	0.422	0.190
HIT-HP SDV-2M22-0210-26	260	80	0.392	0.204
HIT-HP SDV-2M22-0210-28	280	80	0.367	0.218
HIT-HP SDV-2M22-0212				
HIT-HP SDV-2M22-0212-18	180	80	0.575	0.139
HIT-HP SDV-2M22-0212-20	200	80	0.521	0.154
HIT-HP SDV-2M22-0212-22	220	80	0.477	0.168
HIT-HP SDV-2M22-0212-24	240	80	0.440	0.182
HIT-HP SDV-2M22-0212-26	260	80	0.409	0.196
HIT-HP SDV-2M22-0212-28	280	80	0.382	0.209

HALFEN HIT STEEL TO CONCRETE CONNECTOR

Building physics

Thermal values according to Building Authority Approval

HIT Type	Height [mm]	Insulation thickness [mm]	Equivalent thermal conductivity λ_{eq} [W/(mK)]	Equivalent thermal resistance R_{eq} [m ² K/W]
HIT-HP SMV-2M16-0208				
HIT-HP SMV-2M16-0208-18	180	80	0.314	0.255
HIT-HP SMV-2M16-0208-20	200	80	0.286	0.280
HIT-HP SMV-2M16-0208-22	220	80	0.263	0.304
HIT-HP SMV-2M16-0208-24	240	80	0.244	0.327
HIT-HP SMV-2M16-0208-26	260	80	0.228	0.350
HIT-HP SMV-2M16-0208-28	280	80	0.215	0.373
HIT-HP SMV-2M16-0210				
HIT-HP SMV-2M16-0210-18	180	80	0.333	0.240
HIT-HP SMV-2M16-0210-20	200	80	0.304	0.263
HIT-HP SMV-2M16-0210-22	220	80	0.279	0.286
HIT-HP SMV-2M16-0210-24	240	80	0.259	0.309
HIT-HP SMV-2M16-0210-26	260	80	0.242	0.331
HIT-HP SMV-2M16-0210-28	280	80	0.227	0.352
HIT-HP SZV-0208				
HIT-HP SZV-0208-18	180	80	0.202	0.396
HIT-HP SZV-0208-20	200	80	0.186	0.431
HIT-HP SZV-0208-22	220	80	0.172	0.465
HIT-HP SZV-0208-24	240	80	0.161	0.497
HIT-HP SZV-0208-26	260	80	0.151	0.528
HIT-HP SZV-0208-28	280	80	0.143	0.558
HIT-HP SZV-0210				
HIT-HP SZV-0210-18	180	80	0.222	0.360
HIT-HP SZV-0210-20	200	80	0.204	0.393
HIT-HP SZV-0210-22	220	80	0.189	0.424
HIT-HP SZV-0210-24	240	80	0.176	0.455
HIT-HP SZV-0210-26	260	80	0.165	0.484
HIT-HP SZV-0210-28	280	80	0.156	0.512
HIT-HP SZV-0212				
HIT-HP SZV-0212-18	180	80	0.247	0.324
HIT-HP SZV-0212-20	200	80	0.226	0.354
HIT-HP SZV-0212-22	220	80	0.209	0.383
HIT-HP SZV-0212-24	240	80	0.194	0.411
HIT-HP SZV-0212-26	260	80	0.182	0.439
HIT-HP SZV-0212-28	280	80	0.172	0.465

HALFEN HIT STEEL TO CONCRETE CONNECTOR

Building physics

Thermal values according to Building Authority Approval

HIT Type	Height [mm]	Insulation thickness [mm]	Equivalent thermal conductivity λ_{eq} [W/(mK)]	Equivalent thermal resistance R_{eq} [m ² K/W]
HIT-SP SDV-2M16-0208				
HIT-SP SDV-2M16-0208-18	180	120	0.314	0.382
HIT-SP SDV-2M16-0208-20	200	120	0.286	0.420
HIT-SP SDV-2M16-0208-22	220	120	0.263	0.456
HIT-SP SDV-2M16-0208-24	240	120	0.244	0.491
HIT-SP SDV-2M16-0208-26	260	120	0.228	0.525
HIT-SP SDV-2M16-0208-28	280	120	0.215	0.559
HIT-SP SDV-2M16-0210				
HIT-SP SDV-2M16-0210-18	180	120	0.333	0.360
HIT-SP SDV-2M16-0210-20	200	120	0.304	0.395
HIT-SP SDV-2M16-0210-22	220	120	0.279	0.430
HIT-SP SDV-2M16-0210-24	240	120	0.259	0.463
HIT-SP SDV-2M16-0210-26	260	120	0.242	0.496
HIT-SP SDV-2M16-0210-28	280	120	0.227	0.528
HIT-SP SDV-2M22-0208				
HIT-SP SDV-2M22-0208-18	180	120	0.531	0.226
HIT-SP SDV-2M22-0208-20	200	120	0.482	0.249
HIT-SP SDV-2M22-0208-22	220	120	0.441	0.272
HIT-SP SDV-2M22-0208-24	240	120	0.407	0.295
HIT-SP SDV-2M22-0208-26	260	120	0.379	0.317
HIT-SP SDV-2M22-0208-28	280	120	0.354	0.339
HIT-SP SDV-2M22-0210				
HIT-SP SDV-2M22-0210-18	180	120	0.551	0.218
HIT-SP SDV-2M22-0210-20	200	120	0.499	0.240
HIT-SP SDV-2M22-0210-22	220	120	0.457	0.262
HIT-SP SDV-2M22-0210-24	240	120	0.422	0.284
HIT-SP SDV-2M22-0210-26	260	120	0.392	0.306
HIT-SP SDV-2M22-0210-28	280	120	0.367	0.327
HIT-SP SDV-2M22-0212				
HIT-SP SDV-2M22-0212-18	180	120	0.575	0.209
HIT-SP SDV-2M22-0212-20	200	120	0.521	0.230
HIT-SP SDV-2M22-0212-22	220	120	0.477	0.252
HIT-SP SDV-2M22-0212-24	240	120	0.440	0.273
HIT-SP SDV-2M22-0212-26	260	120	0.409	0.293
HIT-SP SDV-2M22-0212-28	280	120	0.382	0.314

HALFEN HIT STEEL TO CONCRETE CONNECTOR

Building physics

Thermal values according to Building Authority Approval

HIT Type	Height [mm]	Insulation thickness [mm]	Equivalent thermal conductivity λ_{eq} [W/(mK)]	Equivalent thermal resistance R_{eq} [m ² K/W]
HIT-SP SMV-2M16-0208				
HIT-SP SMV-2M16-0208-18	180	120	0.314	0.382
HIT-SP SMV-2M16-0208-20	200	120	0.286	0.420
HIT-SP SMV-2M16-0208-22	220	120	0.263	0.456
HIT-SP SMV-2M16-0208-24	240	120	0.244	0.491
HIT-SP SMV-2M16-0208-26	260	120	0.228	0.525
HIT-SP SMV-2M16-0208-28	280	120	0.215	0.559
HIT-SP SMV-2M16-0210				
HIT-SP SMV-2M16-0210-18	180	120	0.333	0.360
HIT-SP SMV-2M16-0210-20	200	120	0.304	0.395
HIT-SP SMV-2M16-0210-22	220	120	0.279	0.430
HIT-SP SMV-2M16-0210-24	240	120	0.259	0.463
HIT-SP SMV-2M16-0210-26	260	120	0.242	0.496
HIT-SP SMV-2M16-0210-28	280	120	0.227	0.528
HIT-SP SZV-0208				
HIT-SP SZV-0208-18	180	120	0.202	0.594
HIT-SP SZV-0208-20	200	120	0.186	0.647
HIT-SP SZV-0208-22	220	120	0.172	0.697
HIT-SP SZV-0208-24	240	120	0.161	0.746
HIT-SP SZV-0208-26	260	120	0.151	0.793
HIT-SP SZV-0208-28	280	120	0.143	0.838
HIT-SP SZV-0210				
HIT-SP SZV-0210-18	180	120	0.222	0.540
HIT-SP SZV-0210-20	200	120	0.204	0.589
HIT-SP SZV-0210-22	220	120	0.189	0.636
HIT-SP SZV-0210-24	240	120	0.176	0.682
HIT-SP SZV-0210-26	260	120	0.165	0.726
HIT-SP SZV-0210-28	280	120	0.156	0.768
HIT-SP SZV-0212				
HIT-SP SZV-0212-18	180	120	0.247	0.486
HIT-SP SZV-0212-20	200	120	0.226	0.531
HIT-SP SZV-0212-22	220	120	0.209	0.575
HIT-SP SZV-0212-24	240	120	0.194	0.617
HIT-SP SZV-0212-26	260	120	0.182	0.658
HIT-SP SZV-0212-28	280	120	0.172	0.698

HALFEN HIT STEEL TO CONCRETE CONNECTOR

Building physics

Thermal bridge characteristic values for HIT-HP and wall masonry with ETICS*

The thermal bridge coefficients for the local heat transfer coefficients χ and the minimum surface temperature Θ_{si} as well as the temperature factor $f_{R,si}$ have been calculated for a wall construction using ETICS* and are available in the table.

*ETICS External Thermal Insulation Composite System.

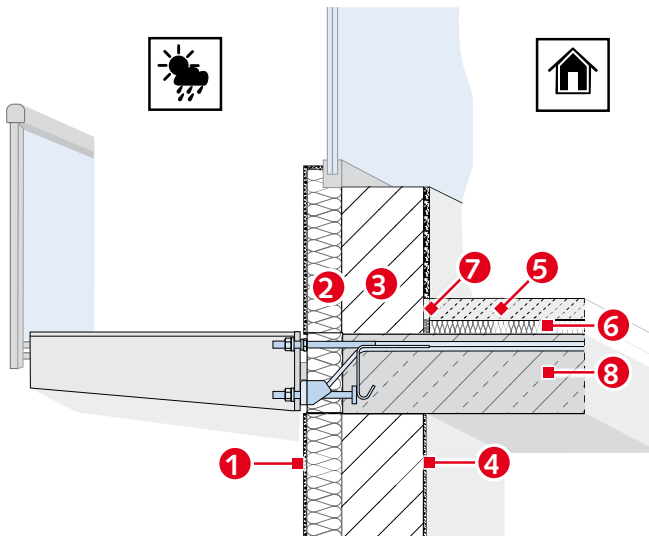

Section details

Wall details

- 1 plaster (exterior)
- 2 insulation
- 3 load bearing wall
- 4 plaster (interior)

Floor details

- 5 screed
- 6 footfall insulation
- 7 edge insulation strips
- 8 floor slab

$U_{uninterrupted} = 0,193 \text{ W}/(\text{m}^2\text{K})$

Wall detail

Masonry with ETICS external thermal insulation composite system

HIT Type	Height [mm]	Insulation thickness [mm]	λ_{eq} [W/(mK)]	R_{eq} [m ² K/W]	min. Θ_{si} [°C]	$f_{R,si}$ [-]	χ [W/K]
HIT-HP SDV-2M16-0208							
HIT-HP SDV-2M16-0208-20	200	80	0.286	0.280	18.710	0.948	0.115
HIT-HP SDV-2M16-0208-28	280	80	0.215	0.373	18.760	0.950	0.123
HIT-HP SDV-2M16-0210							
HIT-HP SDV-2M16-0210-20	200	80	0.304	0.263	18.680	0.947	0.121
HIT-HP SDV-2M16-0210-28	280	80	0.227	0.352	18.730	0.949	0.128
HIT-HP SDV-2M22-0210							
HIT-HP SDV-2M22-0210-20	200	80	0.499	0.160	18.400	0.936	0.168
HIT-HP SDV-2M22-0210-28	280	80	0.367	0.218	18.470	0.939	0.179
HIT-HP SDV-2M22-0212							
HIT-HP SDV-2M22-0212-20	200	80	0.521	0.154	18.360	0.934	0.175
HIT-HP SDV-2M22-0212-28	280	80	0.382	0.209	18.440	0.938	0.183

HALFEN HIT STEEL TO CONCRETE CONNECTOR

Building physics

Thermal bridge characteristic values for HIT-HP and wall masonry with ETICS

HIT Type	Height [mm]	Insulation thickness [mm]	λ_{eq} [W/(mK)]	R_{eq} [m ² K/W]	min. θ_{si} [°C]	$f_{R,si}$ [-]	χ [W/K]
HIT-HP SMV-2M16-0208							
HIT-HP SMV-2M16-0208-20	200	80	0.286	0.280	18.710	0.948	0.115
HIT-HP SMV-2M16-0208-28	280	80	0.215	0.373	18.760	0.950	0.123
HIT-HP SMV-2M16-0210							
HIT-HP SMV-2M16-0210-20	200	80	0.304	0.263	18.680	0.947	0.121
HIT-HP SMV-2M16-0210-28	280	80	0.227	0.352	18.730	0.949	0.128
HIT-HP SZV-0208							
HIT-HP SZV-0208-20	200	80	0.186	0.431	18.920	0.957	0.083
HIT-HP SZV-0208-28	280	80	0.143	0.558	18.930	0.957	0.090
HIT-HP SZV-0210							
HIT-HP SZV-0210-20	200	80	0.204	0.393	18.880	0.955	0.089
HIT-HP SZV-0210-28	280	80	0.156	0.512	18.900	0.956	0.096
HIT-HP SZV-0212							
HIT-HP SZV-0212-20	200	80	0.226	0.354	18.840	0.954	0.095
HIT-HP SZV-0212-28	280	80	0.172	0.465	18.870	0.955	0.103

HALFEN HIT STEEL TO CONCRETE CONNECTOR

Building physics

Thermal bridge characteristic values for HIT-SP and wall masonry with ETICS

HIT Type	Height [mm]	Insulation thickness [mm]	λ_{eq} [W/(mK)]	R_{eq} [m ² K/W]	min. θ_{si} [°C]	$f_{R,si}$ [-]	χ [W/K]
HIT-SP SDV-2M16-0208							
HIT-SP SDV-2M16-0208-20	200	120	0.286	0.420	18.910	0.956	0.806
HIT-SP SDV-2M16-0208-28	280	120	0.215	0.559	18.950	0.958	0.084
HIT-SP SDV-2M16-0210							
HIT-SP SDV-2M16-0210-20	200	120	0.304	0.395	18.890	0.956	0.085
HIT-SP SDV-2M16-0210-28	280	120	0.227	0.528	18.930	0.957	0.088
HIT-SP SDV-2M22-0210							
HIT-SP SDV-2M22-0210-20	200	120	0.499	0.240	18.640	0.946	0.126
HIT-SP SDV-2M22-0210-28	280	120	0.367	0.327	18.710	0.948	0.131
HIT-SP SDV-2M22-0212							
HIT-SP SDV-2M22-0212-20	200	120	0.521	0.230	18.620	0.945	0.130
HIT-SP SDV-2M22-0212-28	280	120	0.382	0.314	18.680	0.947	0.135
HIT-SP SMV-2M16-0208							
HIT-SP SMV-2M16-0208-20	200	120	0.286	0.420	18.910	0.956	0.806
HIT-SP SMV-2M16-0208-28	280	120	0.215	0.559	18.950	0.958	0.084
HIT-SP SMV-2M16-0210							
HIT-SP SMV-2M16-0210-20	200	120	0.304	0.395	18.890	0.956	0.085
HIT-SP SMV-2M16-0210-28	280	120	0.227	0.528	18.930	0.957	0.088
HIT-SP SZV-0208							
HIT-SP SZV-0208-20	200	120	0.186	0.647	19.070	0.963	0.055
HIT-SP SZV-0208-28	280	120	0.143	0.838	19.090	0.964	0.058
HIT-SP SZV-0210							
HIT-SP SZV-0210-20	200	120	0.204	0.589	19.050	0.962	0.059
HIT-SP SZV-0210-28	280	120	0.156	0.768	19.060	0.962	0.063
HIT-SP SZV-0212							
HIT-SP SZV-0212-20	200	120	0.226	0.531	19.010	0.960	0.065
HIT-SP SZV-0212-28	280	120	0.172	0.698	19.030	0.961	0.069



Leviat[®]
A CRH COMPANY

**Innovative engineered products and construction solutions
that allow the industry to build safer, stronger and faster.**

Worldwide contacts for Leviat:

Australia

Leviat
98 Kurrajong Avenue,
Mount Druitt Sydney, NSW 2770
Tel: +61 - 2 8808 3100
Email: info.au@leviat.com

Austria

Leviat
Leonard-Bernstein-Str. 10
Saturn Tower, 1220 Wien
Tel: +43 - 1 - 259 6770
Email: info.at@leviat.com

Belgium

Leviat
Borkelstraat 131
2900 Schoten
Tel: +32 - 3 - 658 07 20
Email: info.be@leviat.com

China

Leviat
Room 601 Tower D, Vantone Centre
No. A6 Chao Yang Men Wai Street
Chaoyang District
Beijing · P.R. China 100020
Tel: +86 - 10 5907 3200
Email: info.cn@leviat.com

Czech Republic

Leviat
Business Center Šafránková
Šafránková 1238/1
155 00 Praha 5
Tel: +420 - 311 - 690 060
Email: info.cz@leviat.com

France

Leviat
18, rue Goubet
75019 Paris
Tel: +33 - 1 - 44 52 31 00
Email: info.fr@leviat.com

Germany

Leviat
Liebigstrasse 14
40764 Langenfeld
Tel: +49 - 2173 - 970 - 0
Email: info.de@leviat.com

Italy

Leviat
Via F.lli Bronzetti N° 28
24124 Bergamo
Tel: +39 - 035 - 0760711
Email: info.it@leviat.com

Malaysia

Leviat
28 Jalan Anggerik Mokara 31/59
Kota Kemuning, 40460 Shah Alam
Selangor
Tel: +603 - 5122 4182
Email: info.my@leviat.com

Netherlands

Leviat
Oostermaat 3
7623 CS Borne
Tel: +31 - 74 - 267 14 49
Email: info.nl@leviat.com

New Zealand

Leviat
2/19 Nuttall Drive, Hillsborough,
Christchurch 8022
Tel: +64 - 3 376 5205
Email: info.nz@leviat.com

Norway

Leviat
Vestre Svanholmen 5
4313 Sandnes
Tel: +47 - 51 82 34 00
Email: info.no@leviat.com

Poland

Leviat
Ul. Obornicka 287
60-691 Poznan
Tel: +48 - 61 - 622 14 14
Email: info.pl@leviat.com

Singapore

Leviat
14 Benoi Crescent
Singapore 629977
Tel: +65 - 6266 6802
Email: info.sg@leviat.com

Spain

Leviat
Polígono Industrial Santa Ana
c/ Ignacio Zuloaga, 20
28522 Rivas-Vaciamadrid
Tel: +34 - 91 632 18 40
Email: info.es@leviat.com

Sweden

Leviat
Vädursgatan 5
412 50 Göteborg
Tel: +46 - 31 - 98 58 00
Email: info.se@leviat.com

Switzerland

Leviat
Hertistrasse 25
8304 Wallisellen
Tel: +41 - 44 - 849 78 78
Email: info.ch@leviat.com

United Kingdom

Leviat
A1/A2 Portland Close
Houghton Regis LU5 5AW
Tel: +44 - 1582 - 470 300
E-Mail: info.uk@leviat.com

United States of America

Leviat
6467 S Falkenburg Rd.
Riverview, FL 33578
Tel: (800) 423-9140
Email: info.us@leviat.us

For countries not listed

Email: info@leviat.com

Leviat.com

For information on certified management systems and standards see www.ancon.co.uk | www.aschwanden.com | www.halfen.com

Notes regarding this catalogue

© Protected by copyright. The construction applications and details provided in this publication are indicative only. In every case, project working details should be entrusted to appropriately qualified and experienced persons. Whilst every care has been exercised in the preparation of this publication to ensure that any advice, recommendations or information is accurate, no liability or responsibility of any kind is accepted by Leviat for inaccuracies or printing errors. Technical and design changes are reserved. With a policy of continuous product development, Leviat reserves the right to modify product design and specification at any time.



Imagine. Model. Make.

Leviat.com