



ETA-Danmark A/S
Göteborg Plads 1
DK-2150 Nordhavn
Tel. +45 72 24 59 00
Internet www.etadanmark.dk

Authorised and notified
according to Article 29 of the
Regulation (EU)
No 305/2011 of the European
Parliament and of the Council
of 9 March 2011

MEMBER OF EOTA



European Technical Assessment ETA-20/0910 of 2022/03/04

I General Part

Technical Assessment Body issuing the ETA and designated according to Article 29 of the Regulation (EU) No 305/2011: ETA-Danmark A/S

Trade name of the construction product:

In-situ Concrete Slab Permanent Joint Formers

Product family to which the above construction product belongs:

Structural metallic products and ancillaries

Manufacturer:

Leviat LTD
President Way
President Park
Sheffield
S4 7UR
United Kingdom
Telephone: +44 1458 270600
www.isedio.com

Manufacturing plant:

Unit 10 Jubilee Park
Badger's Cross Lane
Somerton
UK TA11 7JF Somerset
United Kingdom

This European Technical Assessment contains:

21 pages including 3 annexes which form an integral part of the document

This European Technical Assessment is issued in accordance with Regulation (EU) No 305/2011, on the basis of:

European Assessment document (EAD) no. EAD 200089-00-0302 for In-situ Concrete Slab Permanent Joint Former

This version replaces:

The ETA with the same number issued on 2020-11-30

Translations of this European Technical Assessment in other languages shall fully correspond to the original issued document and should be identified as such.

Communication of this European Technical Assessment, including transmission by electronic means, shall be in full [except the confidential Annex(es) referred to above]. However, partial reproduction may be made with the written consent of the issuing Technical Assessment Body. Any partial reproduction has to be identified as such.

1 Technical description of the product

1.1 General

In-situ Concrete Slab Permanent Joint Formers (see Annex A) are leave-in-place joint systems comprising:

- divider plate — physically constrains the concrete during the casting process, can be of fixed depth or adjustable two-part divider plate
- dowels (load transfer mechanisms) — may be metal round or square cross section bar, or metal square plate dowels for free movement or tied joints. Free movement joints (see Section 1.2) have factory fitted dowels that are welded to the divider plate or factory fastened to the divider plate using bracketry with mechanical fixings. Free movement joint formers have plastic or metal sleeves fitted to the dowels on one side of the joint former only (the free-side of the joint). Free movement joints must have horizontal dowels across the joint with sleeves on one side of the joint in order to facilitate joint opening and load transfer across the joint. For Tied joints (see Section 1.2) metal dowels pass through the divider plate at regular intervals and transfer the load across the joint without the need for joint opening
- slab edge protection — used only in the case of formed free movement joints. Formed free movement joints have edge protection to prolong the life of the exposed slab panel edges as the slab panels shrink away from the joint during the curing process. Edge protection is provided to either reinforce the edges of the slab panels against impact loads from mechanical handling equipment (MHE) or to eliminate the impact load entirely. The edge protection designs are either: solid steel top strip with drawn-arc welded shear studs used to anchor the strips in to the concrete; or a rolled/folded top strip with either a perforated section that extends from the edge protection from below the finished floor level into the concrete to afford anchorage of the edge protection in to the concrete and a folded steel edge with tangs for anchorage into the concrete; or a horizontal plate with a wave shaped split line, thus ensuring the MHE is always in contact with both sides of the joint as the MHE traverses the joint.

In-situ Concrete Slab Permanent Joint Formers are manufactured predominantly from mild steel, galvanized mild steel, stainless steel or a combination of these materials and assembled using plastic fasteners. Joint formers can be designed for free movement joints or tied joints and are available in four types: Armourjoint, Expajoint, Shieldjoint and Steeldeckjoint. The joint types are described in Section 1.3 and Annex A of this ETA.

1.2 Formed free movement joints vs tied joints

Free movement joints are required where the floor is designed such that it is constructed from more than one slab panel and each slab panel must be able to shrink and move freely during the construction process and in service. Any restraint to the free movement of the slab panels may cause over-stressing of the concrete leading to cracking. Typically, the joint former is used on ground-slabs supported by the sub-base or piles. The joint former must be capable of providing edge/arris protection to both of the slab panels either side of the joint. Therefore, the joint former will be designed to separate into two sub-assemblies such that each sub-assembly is anchored in to the respective slab panel. As the slab panels cure and shrink, they pull away from each other and each slab panel retains its respective sub-assembly of the joint former. Typically, the dowel will stay with one slab panel and a mating metal or plastic sleeve stays in the adjacent slab panel. The metal or plastic sleeve allows the slab panel to decouple from the joint former sub-assembly that retains the dowel. The side of the joint former that has the sleeve is called the 'free side'. The edge protection sub-divides with one part retained in each adjacent slab panel.

Free-movement joints are usually provided to coincide with a planned concrete pour or to maintain an acceptable aspect ratio of the floor panel.

Tied joints are designed to allow adjacent slab panels to be tied across the joint former. Tied joints are used where no joint opening is required. Dowels do not need to be horizontal across the joint and are fitted on site by pushing the dowel through the divider plate into fresh concrete on the other side of the joint former. Tied joints allow no free movement across the joint and bond the slab panels either side of the joint to each other. Therefore, a joint former for a tied joint requires no edge protection and no sleeves are required on the dowels, as they do not need to decouple.

1.3 Types of in-situ concrete slab permanent joint formers

Armourjoint

Armourjoint (see Annex A [A1] and Figures A1.1 to A1.9) is a leave-in-place permanent joint former manufactured predominantly from mild steel, pre-galvanized mild steel, hot dip galvanized steel or stainless steel or a combination of these materials, and assembled using plastic fasteners and plastic or metal sleeves (see Table A1). Armourjoint is used where a free movement joint is required but can be adapted to be used where a tied joint is required. When used for external applications Armourjoint can be supplied with pre-installed Miothene foam (5, 10, 15, 20, 25 or 30 mm thick) to the full depth of the joint (or greater) or a 40 mm band at the top and bottom of the joint. The foam allows in-service thermal expansion of the cast slab panels due to variations in ambient temperature.

Expajoint

Expajoint (see Annex A [A2] and Figures A2.1 to A2.2) is a leave-in-place permanent joint former manufactured predominantly from mild steel, pre-galvanized steel, hot dip galvanized steel, stainless steel or a combination of these materials, and assembled using plastic fasteners and plastic or metal sleeves (see Table A2). Expajoint is used where a free movement joint is required. When used for external applications, Expajoint can be supplied with pre-installed Miothene foam (5, 10, 15, 20, 25 or 30 mm thick) to the full depth of the joint (or greater) or a 40 mm band of foam at the top and bottom of the divider plate. This foam allows in-service thermal expansion of the cast slab panels due to variations in ambient temperature.

Shieldjoint

Shieldjoint (see Annex A [A3] Figures A3.1 to A3.4) is a leave-in-place permanent joint former manufactured predominantly from mild steel, pre-galvanized mild steel, hot dip galvanized steel, stainless steel or a combination of these materials and assembled using plastic fasteners and plastic or metal sleeves. Shieldjoint is used where a free movement joint is required. When used for external applications, Shieldjoint can be supplied with pre-installed Miothene foam (5, 10, 15, 20, 25 or 30mm thick) to the full depth of the joint (or greater). This foam allows in-service thermal expansion of the cast slab panels due to variations in ambient temperature.

Steeldeckjoint

Steeldeckjoint (see Annex A [A4] Figure A4.1) is a leave-in-place permanent joint former. Steeldeckjoint is used where a tied joint is required. It is not designed to allow free movement of slabs panels either side of the joint.

2 Specification of the intended use(s) in accordance with the applicable European Assessment Document (hereinafter EAD)

In-situ Concrete Slab Permanent Joint Formers provide continuity of load transfer across the joint and slab panel edge reinforcement for continuation of slab serviceability during its life. Edge reinforcement prolongs the life of the slab panel edge/arris and load transfer ensures minimisation of differential vertical deflection between slab panel edges when subject to both dynamic and static loads in service.

The edges of slab panels are vulnerable to damage caused by the passage of MHE, with wider joints being more susceptible. The small hard wheels on pallet trucks and similar trucks are particularly aggressive. Therefore, protection of the slab panels edges/arrises is paramount. Elimination of the impact load is superior to protection against the impact load.

The number and type of joints in a floor will depend on the floor construction method and its design. The method chosen should be related to the planned use of the floor and other factors.

A free-movement joint should be provided between a floor slab and an adjoining structure where the adjoining structure forms part of the floor surface trafficked by MHE and are designed to provide a minimum of restraint to horizontal movements caused by drying shrinkage and temperature changes in the slab, while restricting relative vertical movement. Load transfer mechanisms such as dowels provide load transfer across the joint. Load transfer mechanisms including dowels and dowel sleeves should be engineered to minimise vertical movement and must be incorporated in to the joint during manufacture at the factory.

Tied joints are used where no free movement is required as the slab will be mechanically bonded to the element on which it is being cast, i.e. composite slab constructions such as concrete slabs on steel decking, concrete slabs on concrete beams or concrete over-slabs on existing slabs.

The load-carrying capacities of a slab at a free edge and at a free corner are approximately 50% and 25% of the capacity at the centre of the slab respectively. True free edges or corners that are required to carry loads are relatively unusual, as they generally occur only at the periphery of a building. Joints between panels and the intersections of these joints are required to transfer load across them ('load-transfer capacity'), and to prevent differential vertical movement. The joint formers assessed in this ETA form "free-movement joints" and/or "tied joints".

Manufacturing of the joint formers

Manufacturing drawings are required in the production of joint formers. The production process includes the control monitoring of the final dimensions of components and quality control of the welding. After the completion of the production of individual parts, a check is performed to ensure the components are compliant to the drawings. The assembly is then produced and a check of the functionality of the assembly undertaken to prove it will work in service.

Design

The joint former design may be a standard design or a bespoke design to cater for the specific project needs. The design of the joint former is based on the specifications of the intended use, the expected maximum joint opening (if any), the environment, the required load transfer across the joint and the slab depth.

Packaging, transport and storage

Palletisation of the joint formers is undertaken at the factory by trained operators. The completed pallet of joint formers can either be shrink wrapped and/or the joint formers coated with a rust preventative. Each pallet is banded for safe handling and transportation. Truck loading of the pallet on to transportation is undertaken by trained operators using MHE. Unloading at the construction site is performed by trained operators using MHE. Once delivered to site, the joint formers must be protected from weather, damage during handling and possible damage during removal onto the prepared site. The joint formers should be stored in dry and sheltered conditions, at least 100 mm off the ground.

Use, maintenance and repairs

Before use, the joint formers are inspected visually for completeness and any signs of damage that might have occurred during transport or storage. For each delivery, the manufacturer includes relevant information and instructions for use.

The assessment of the products is based on the assumption that during the estimated life expectancy no product maintenance is required, though regular checks should be carried out on the slab surface to ensure that any damage is detected and repaired as soon as possible.

In case of a repair, it is necessary to perform an assessment for mechanical resistance and stability.

The provisions made in this European Technical Assessment are based on an assumed working life for the joint formers of 50 years. The indications given in the working life cannot be interpreted as a guarantee given by the producer or the Technical Assessment Body, but are to be regarded only as a means for choosing the right products in relation to the expected economically reasonable working life of the works.

3 Performance of the product and references to the methods used for its assessment

3.1 Mechanical resistance and stability (BWR 1)

3.1.1 Load transfer capacity

Load-transfer capacity is principally dependent on the load transfer mechanism of the joint. Sub-base support may have some influence, but it is not typically considered in the design process. Joint load transfer mechanisms can consist of round dowel bars or square dowel bars or square plate dowels.

The movement of MHE will cause some relative deflection across joints. Joints should be designed to reduce this to a negligible amount.

A load transfer mechanism design must take into account the effective depth of the concrete that surrounds it when considering bearing and burst-out capacity.

The ultimate theoretical load transfer capacity of the joints is dependent on the compressive strength of concrete, the geometry of the dowel, the dimension of the maximum joint opening and strength of the dowel material at yield (see Annex B). However, the yield strength of the dowels has been declared to enable the appropriately qualified design engineer to calculate the load transfer capacity.

3.1.2 Durability

The durability of the products depends on durability of the materials used. The part of the floor in which the joint systems are intended to be installed or applied must be assessed according to their chemical composition, thickness of material layers, intended use, concrete cover thickness and the environmental exposure to which they are subject. To assess the durability, the following cases must be considered:

- mild steel can be used for indoor applications where the joint former will not be in contact with standing water
- galvanized or mild steel elements can be used floors with a minimum 30 mm concrete cover
- galvanized steel must have minimum of 25 µm galvanized coating if not covered by a minimum 30 mm concrete cover for floors exposed to frequently wet or corrosive conditions
- galvanized steel must have minimum of 85 µm galvanized coating if not covered by a minimum 30 mm concrete cover for continuously wet floors
- stainless steel products can be considered fit for purpose from durability aspect.

If all products assessed comply with these requirements, no further investigation regarding durability is required.

3.1.3 Dimensions, tolerances on dimensions and shape, mass

The tolerances for dimension of the steel components of the system are +/- 0.5mm for dimensions less than 100 mm and +/- 1.0 mm for dimensions 100 mm or greater unless otherwise stated. The tolerances for angles between the system components are +/- 0.5°.

3.2 Safety in case of fire (BWR 2)

No performance assessed

3.3 Hygiene, health and environment (BWR 3)

No performance assessed

3.4 Safety and accessibility in use (BWR4)

No performance assessed

3.5 Protection against noise (BWR 5)

No performance assessed

3.6 Energy economy and heat retention (BWR 6)

3.6.1 Thermal performance

The heat loss associated with elements (U-values) and junctions (ψ -values), incorporating the system, must be determined in accordance with EN ISO 10211 : 2017 (see Annex C).

3.6.2 Condensation risk

The risk of surface condensation for elements and junctions incorporating the system shall be determined in accordance with EN ISO 10211 : 2017 and EN ISO 13788 : 2012 (see Annex C).

3.7 Sustainable use of natural resources (BWR 7)

No performance assessed

4 Assessment and verification of constancy of performance (hereinafter AVCP) system applied, with reference to its legal base

In accordance with European Assessment Document (EAD) No. 16-20-0089.03.02, the applicable European legal act is : 1998/214/EC⁽¹⁾ and amended by Decision 2001/596/EC⁽²⁾ of the European Commission, the system of assessment and verification of constancy of performance [see Annex V to Regulation (EU) No 305/2011] is as follows:

The System to be applied is: 2+

(1) Official Journal of the European Communities L 80 of 18 March 1998.

(2) Official Journal of the European Communities L 209 of 02 August 2001.

5 Technical details necessary for the implementation of the AVCP system, as provided for in the applicable EAD

Technical details necessary for the implementation of the AVCP system are laid down in the control plan deposited at ETA-Danmark A/S prior to CE marking

Issued in Copenhagen on 2022-03-04 by

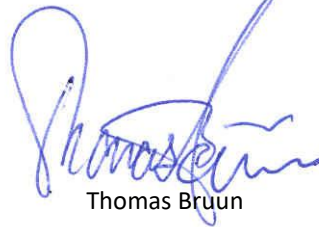

Thomas Bruun

Managing Director, ETA-Danmark

ANNEX A - TYPES OF JOINT FORMERS

The details about the components of the joint former types are presented in this section:

A1 Armourjoint

Armourjoint is supplied in 3 m lengths (see Figures A1.1 to A1.9). Table A1 includes the characteristics of the components of Armourjoint:

Table A1

Component, Description and Specifications	Material	Dimensions	Figures
Solid steel edge protection made from two back-to-back solid steel strips	Cold drawn mild steel strips (S235JR to EN 10277-1 : 2008) or cold drawn stainless steel strips (304 or better)	40 mm deep x 10 mm wide	A1.1 to A1.4
Rolled steel edge protection made from two back-to-back rolled steel strips	Mild steel (minimum yield 235 N·mm ²) or stainless steel (equivalent to 304 or better) rolled/folded top strips. The mild steel edge protection strip can be hot dip galvanized (85 µm minimum to EN ISO 1461 : 2009).	Rolled/folded top strips 2.5 to 5 mm thick to produce a folded 5 to 10 mm top width (with a sharp edge abutting the concrete) x approximately 40 mm deep section that comprises a perforated wing (2.5 to 5 mm thick x approximately 57 mm wide) that extends from the rolled/folded section at least 20 mm down from the top face of the section (the finished floor level) and anchors the edge protection in to the concrete.	A1.5 and A1.6
Shear studs ⁽¹⁾ drawn arc welded for anchorage to the concrete	Mild steel (EN ISO 13918 : 2008 type SD1) or stainless steel (EN ISO 13918 : 2008 type SD3)	10 mm diameter x 100 mm pre-weld length	A1.1 to A1.9
Divider plate: The divider plate can be either a fixed depth divider plate or a two-part adjustable depth divider plate held together in a loose fit condition by a factory fitted metal rivet style fastener that once set cannot be tightened or loosened, such that the adjustable divider plate system can be adjusted on site to the correct depth without the use of any tools.	Mild steel (DC01 to EN 10130 : 2006), pre-galvanized mild steel (DX51D to EN 10346 : 2015) or stainless steel (304 or higher grades)	The thickness of the material can range from 1 to 4 mm depending on the depth of the slab. Fixed depth divider plates are available in any size to suit a joint size of 90 mm upwards. Typically, the adjustable divider plate system is made in 30 or 50 mm increments to create joint sizes such as 100 to 150 mm, 150 to 200 mm, 200 to 250 mm, 250 to 300 mm etc.	A1.1 to A1.9
Dowels ⁽²⁾ : The dowels are Metal Inert Gas (MIG) factory welded to the divider plate or can be factory fitted in place with mechanical fasteners and bracketry.	Mild steel (S275 or S355 to EN 10029 : 2010), hot dip galvanized mild steel (85 µm minimum to EN ISO 1461 : 2009), or stainless steel (304 or higher grades)	6 x 100 x 100 mm, 6 x 150 x 150 mm, 8 x 150 x 150 mm or 12 x 150 x 150 mm thick square plate	A1.1 to A1.9

(1) Each stud weld must be conducted in inert conditions either through the use of welding shield gas at the weld or a ceramic ferrule around the weld pool. Pre-production stud welding checks are to be completed to EN ISO 14555 : 2017. Every stud weld must be tested after welding by applying bend test to the stud such that the weld between the edge protection and the stud is exposed to the bending load and the stud passes through a bend angle of at least 10 degrees from horizontal in a downward direction. The edge protection steel must be cold drawn to ensure the edges of the steel are sharp against the concrete slab. The assembly of the mild steel strip with welded shear studs can be hot dip galvanized (85 µm minimum to EN ISO 1461 : 2009).

(2) Dowels pass through the divider plate on regular intervals. The dowels are positioned through the divider plate such that the 100 x 100 mm size is 40 mm on the fixed side of the joint leaving 60 mm on the free side of the joint allowing for a maximum of 20 mm joint opening, and the 150 x 150 mm size is 60 mm on the fixed side of the joint leaving 90 mm on the free side of the joint allowing for a maximum of 30 mm joint opening.

Figure A1.1 Armourjoint with solid steel edge protection and fixed depth divider plate (view on fixed side of the joint)

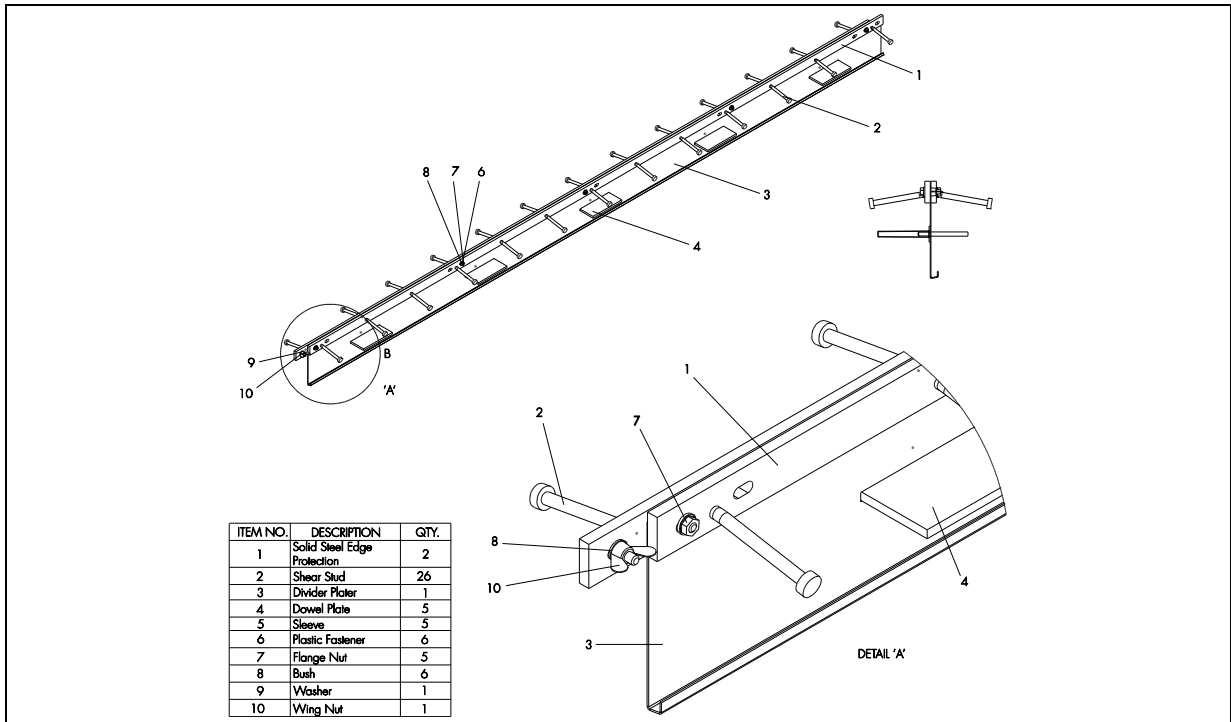

Figure A1.2 Armourjoint with solid steel edge protection and fixed depth divider plate (view on free side of the joint)

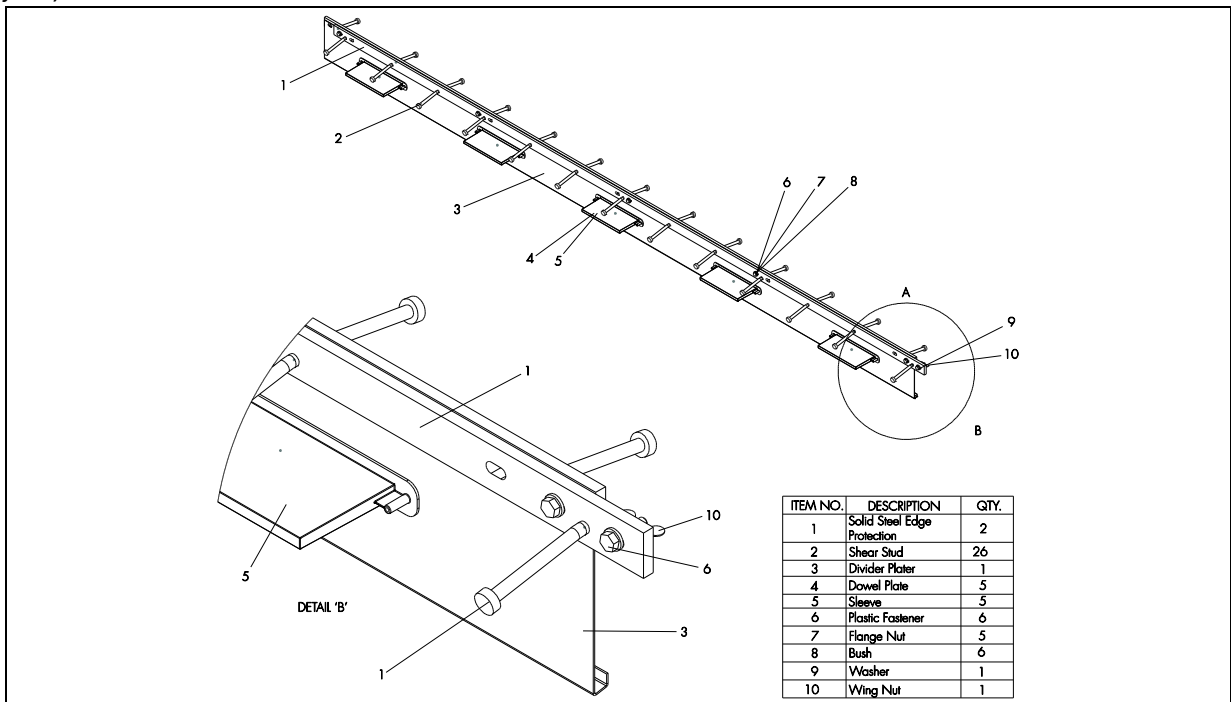

Figure A1.3 Armourjoint with solid steel edge protection and adjustable depth divider plate (view on fixed side of the joint)

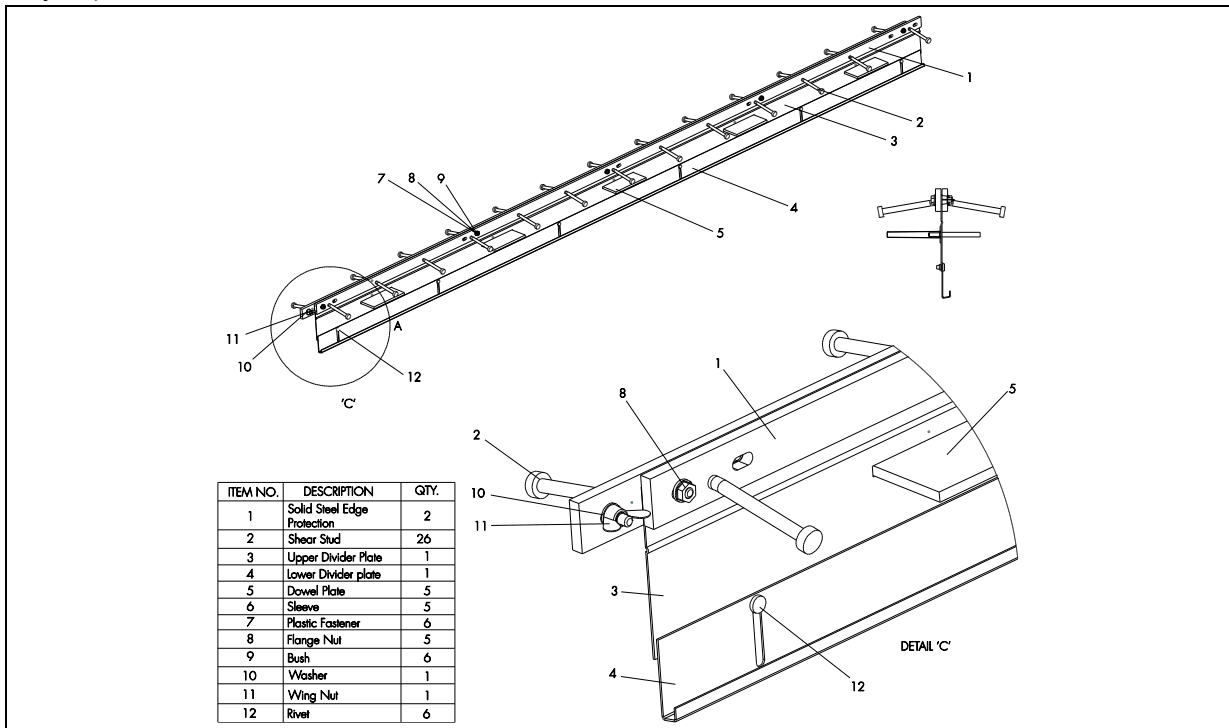

Figure A1.4 Armourjoint with solid steel edge protection and adjustable depth divider plate (view on free side of the joint)

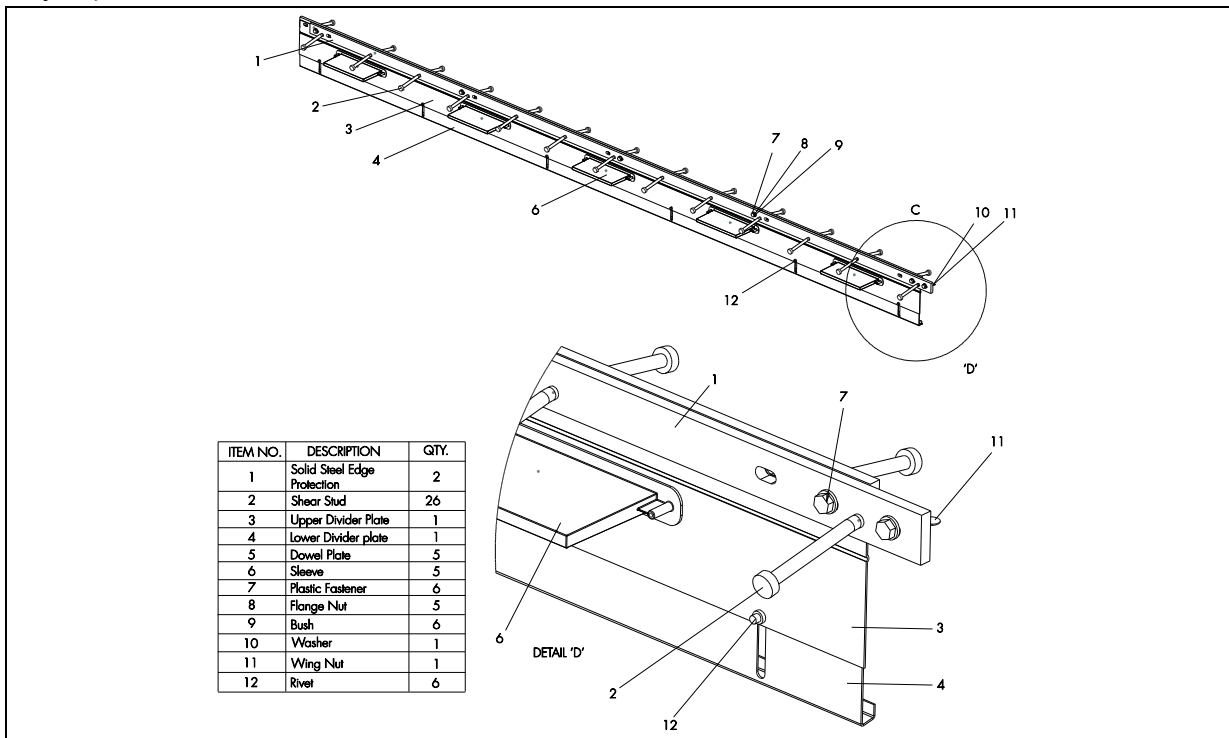

Figure A1.5 Armourjoint with rolled steel edge protection and adjustable depth divider plate (view on fixed side of the joint)

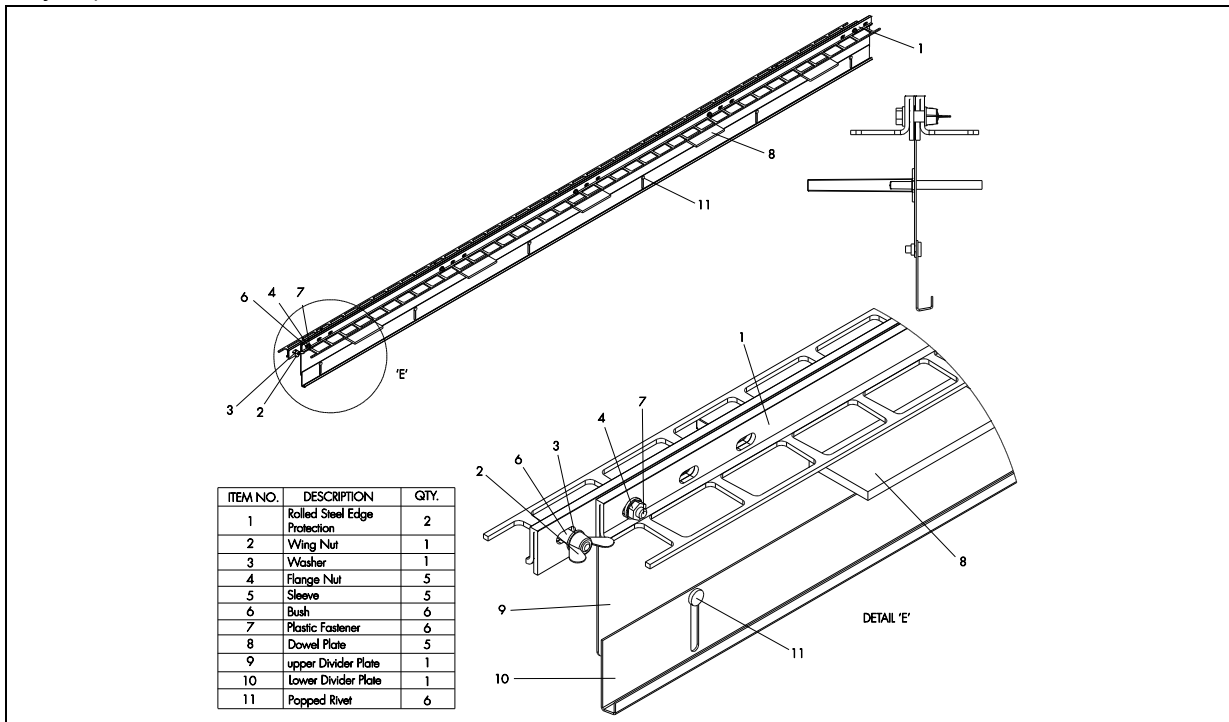
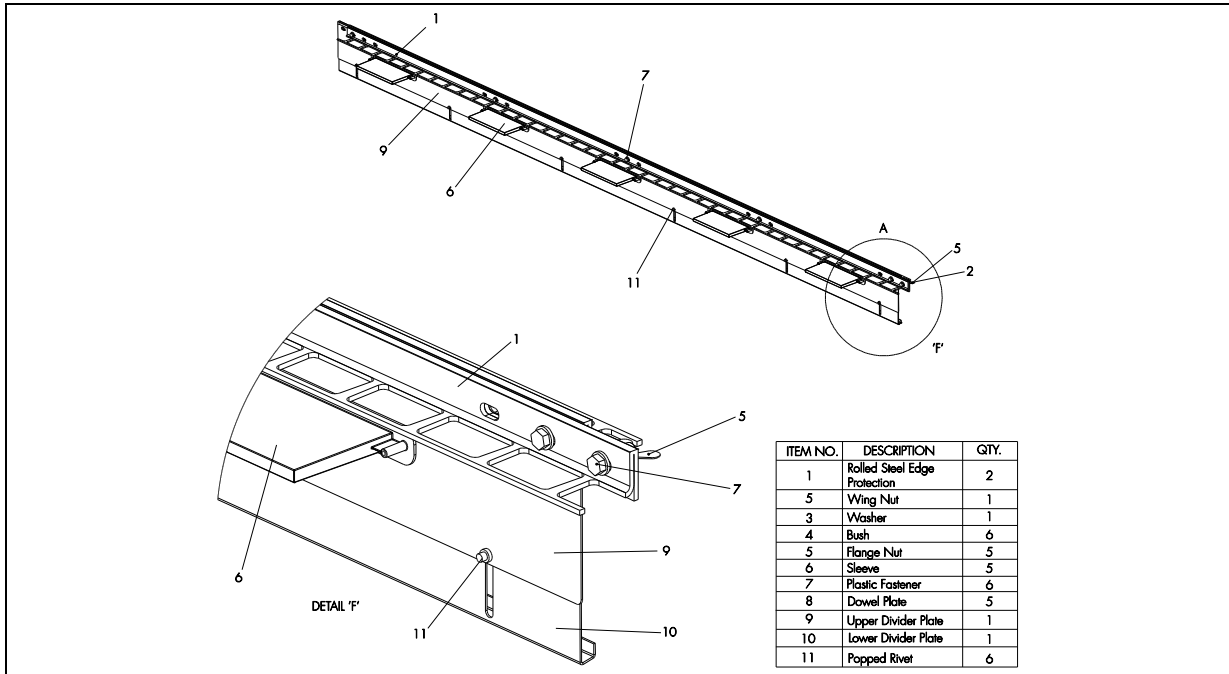

Figure A1.6 Armourjoint with rolled steel edge protection and adjustable depth divider plate (view on free side of the joint)



Where Armourjoints meet at an intersection between slab panels, a four-way tee or corner intersection (see Figures A1.7 to A1.9) must be used. These are made under factory control.

Figure A1.7 Armourjoint corner intersection with solid steel edge protection and adjustable depth divider plate

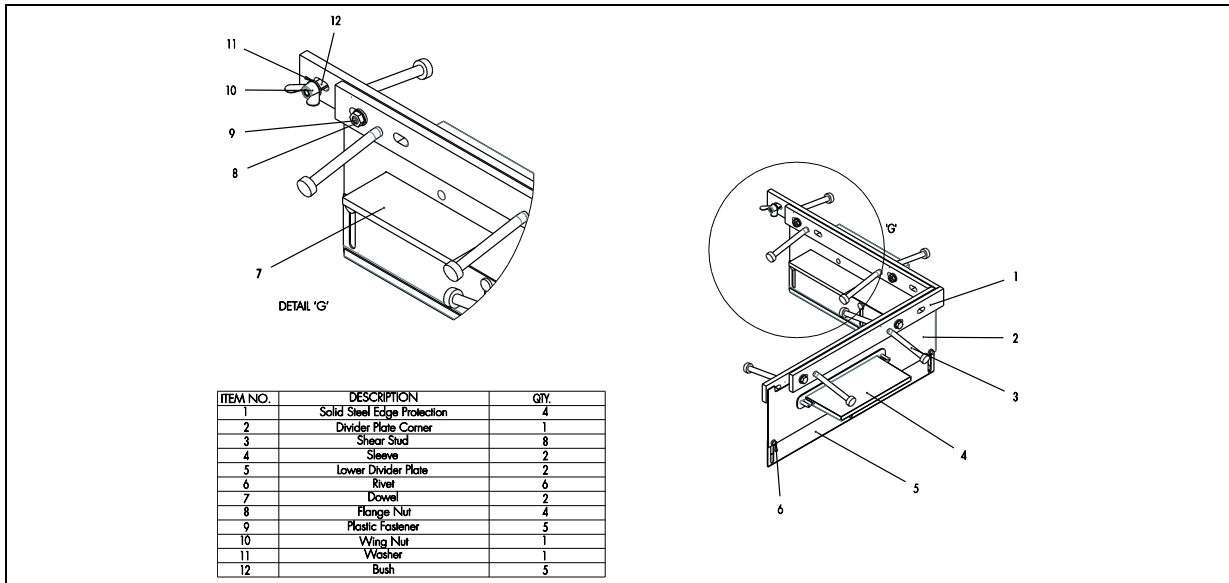

Figure A1.8 Armourjoint tee intersection with solid steel edge protection and adjustable depth divider plate

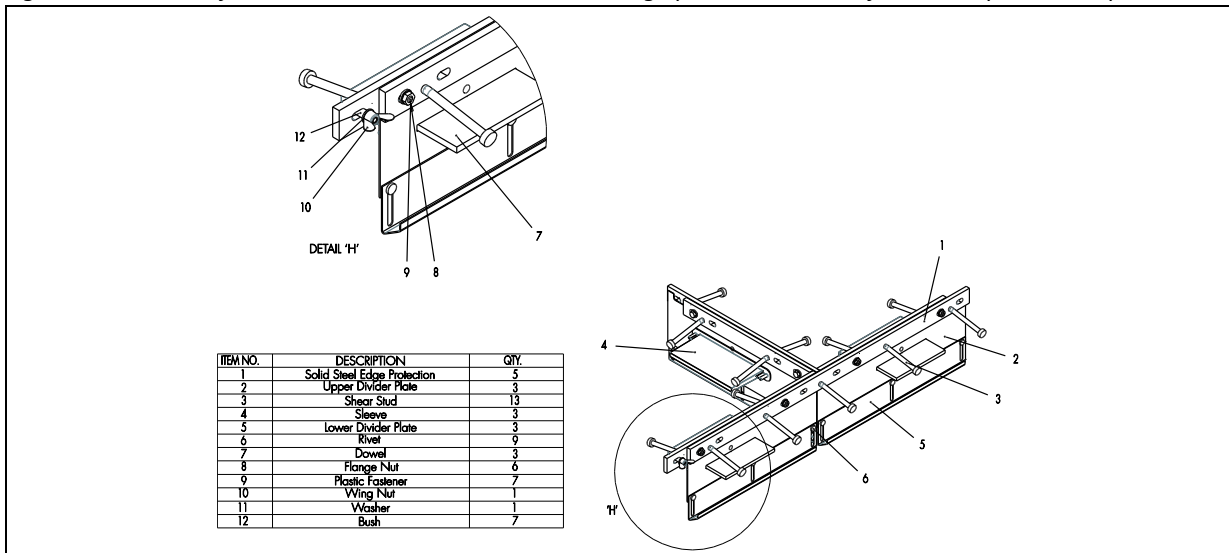
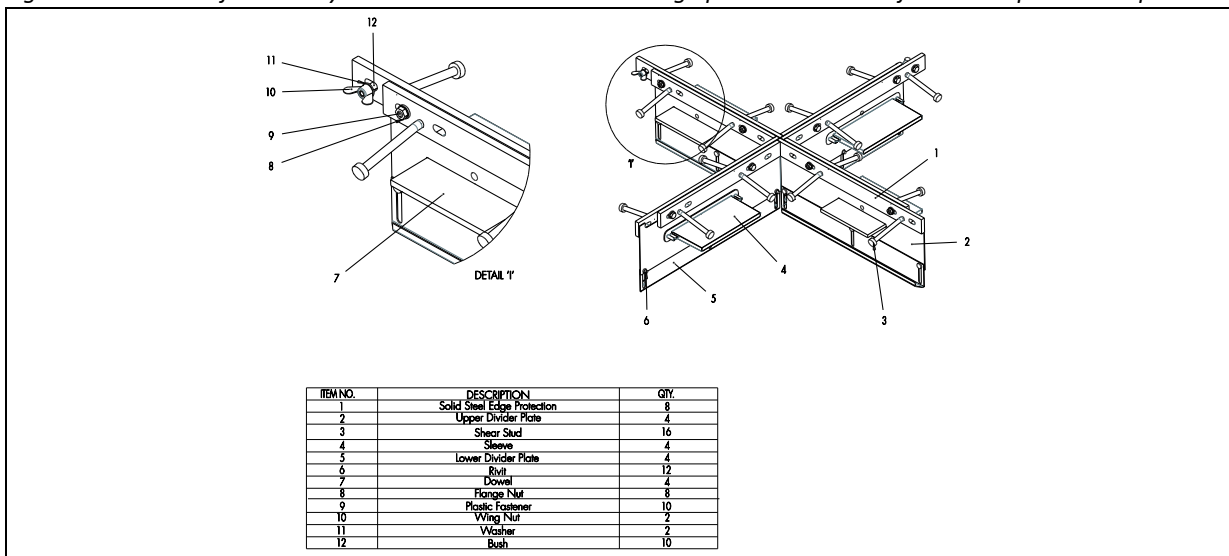

Figure A1.9 Armourjoint 4 way intersection with solid steel edge protection and adjustable depth divider plate



A2 Expajoint

Expajoint is primarily for use in low duty environments such as pneumatic tyre traffic. Expajoint is supplied in 3 m lengths (see Figures A2.1 and A2.2). Where Expajoints meet at an intersection between slab panels, a factory made four way, tee or corner intersection must be used as is the case with Armourjoint. These are made under factory control and on-site construction of intersections must not be undertaken. Table A2 includes the characteristics about the components of Expajoint:

Table A2

Component, Specifications	Description and	Material	Dimensions	Figures
	Divider plate: The joint former comprises two back-to-back divider plates. Each divider plate is anchored to the concrete by the longitudinal shaped edges of the top and bottom folds of each divider plate. The divider plate is a fixed depth divider plate.	Mild steel (DC01 to EN 10130 : 2006), pre-galvanized mild steel (DX51D to EN 10346 : 2015) or stainless steel (304 or higher grades)	The thickness of the material can range from 1 mm to 4 mm depending on the depth of the slab. Fixed depth divider plates are available in any size to suit a joint size of 90 mm upwards.	A2.1 and A2.2
	Dowels ⁽¹⁾ : The dowels are Metal Inert Gas (MIG) factory welded to the divider plate or can be factory fitted in place with mechanical fasteners and bracketry.	Mild steel (S275 or S355 to EN 10029 : 2010), hot dip galvanized mild steel (85 µm minimum to EN ISO 1461 : 2009), or stainless steel (304 or higher grades)	6 x 100 x 100 mm, 6 x 150 x 150 mm, 8 x 150 x 150 mm or 12 x 150 x 150 mm thick square plate	A2.1 and A2.2

(1) Dowels pass through the divider plate on regular intervals. The dowels are positioned through the divider plate such that the 100 x 100 mm size is 40 mm on the fixed side of the joint leaving 60 mm on the free side of the joint allowing for a maximum of 20 mm joint opening, and the 150 x 150 mm size is 60 mm is on the fixed side of the joint leaving 90 mm on the free side of the joint allowing for a maximum of 30 mm joint opening.

Figure A2.1 Expajoint with fixed depth divider plates (view on fixed side of the joint)

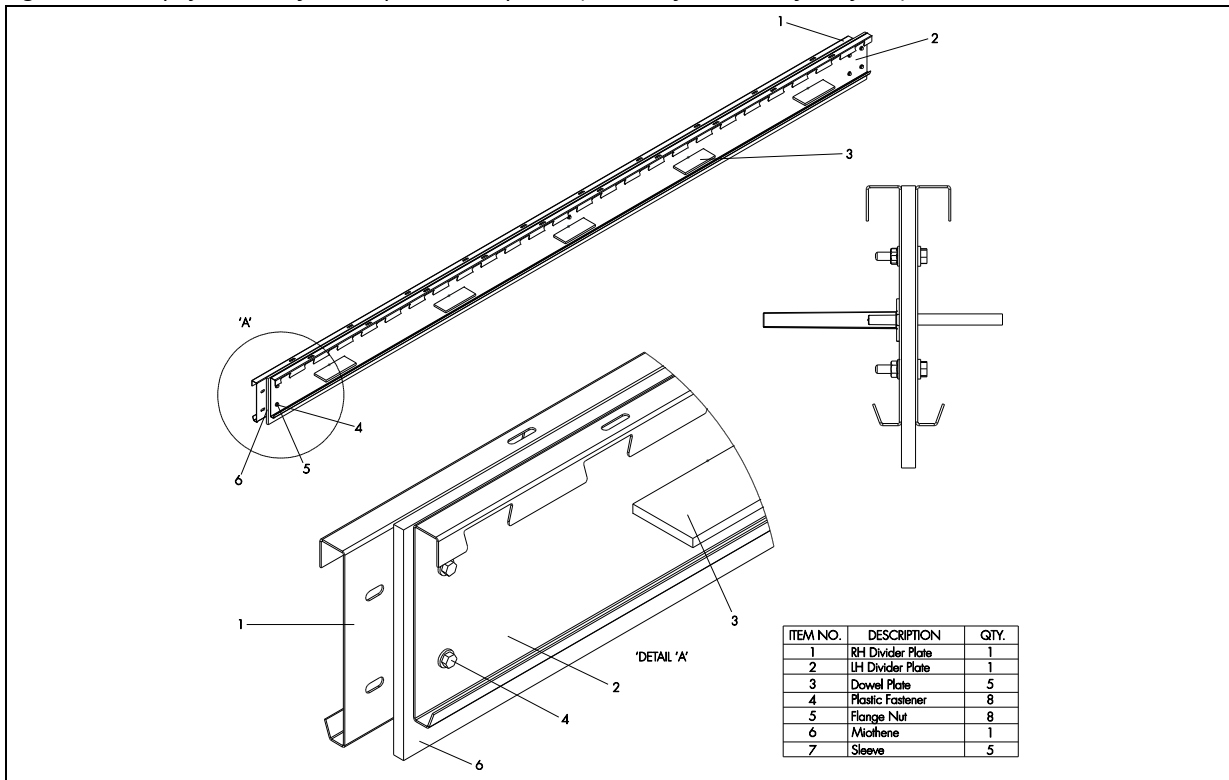
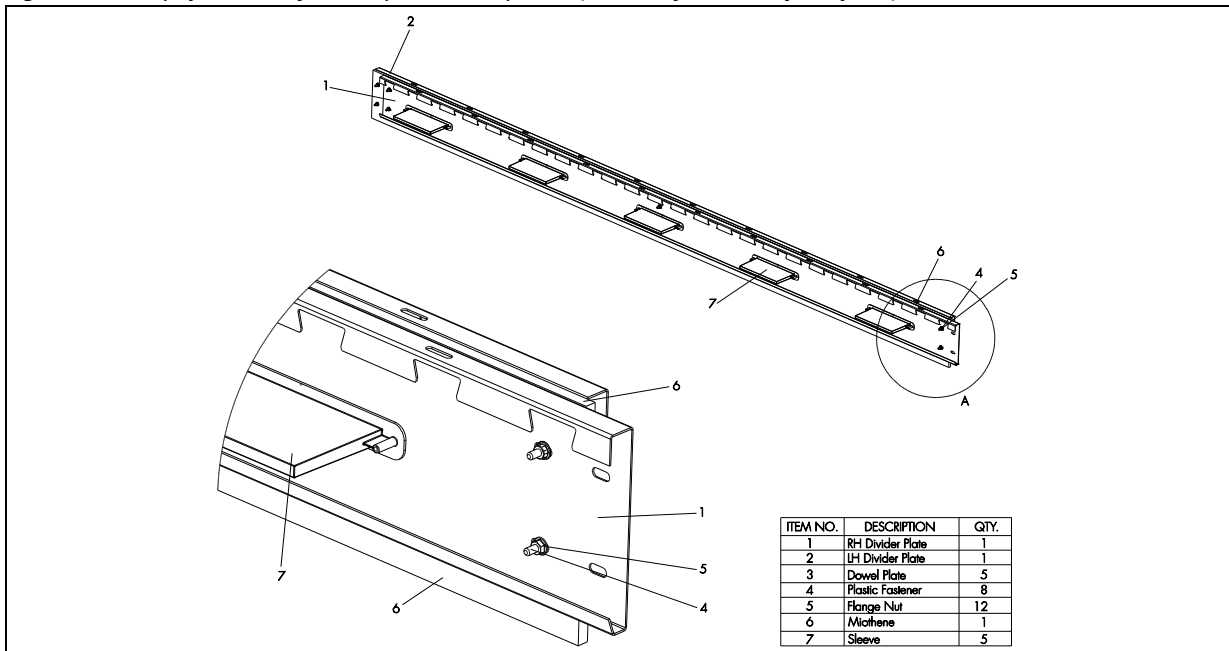

Figure A2.2 Expajoint with fixed depth divider plates (view on free side of the joint)



A3 Shieldjoint

Shieldjoint is supplied in 1.95 m lengths (see Figures A3.1 to A3.3). Table A3 includes the characteristics about the components of Shieldjoint:

Table A3

Component, Description and Specifications	Material	Dimensions	Figures
Top plate: Shieldjoint is supplied with 3 layers of horizontal top plates, each layer comprising two halves with each half mating with the other such that when assembled the 3 layers create two sub-assemblies that can separate horizontally. The layers can either be welded together or fastened by mechanical means. The top plate (4 to 10 mm thick) which is exposed at finished floor level has a non-linear split line running parallel to the direction of the joint. The non-linearity of the split line ensures that any wheeled traffic is always in contact with both sides of the joint top plate and thus eliminates any impact providing a maximum of 25 mm joint opening is not exceeded. Bespoke versions of Shieldjoint can be made for larger joint openings. Edge protection is afforded by elimination of any impact loads. Beneath the top plate with the non-linear split line is a set of intermediate plates (4 to 6 mm thick) and beneath the intermediate plates are a pair of back-to back sections (3 to 5 mm thick) with upper and lower perforated angled wings which anchor in to the concrete.	Mild steel or stainless steel. The mild steel can be hot tip galvanized (85 µm minimum to EN ISO 1461 : 2009)	100 to 200 mm wide	A3.1 and A3.2
Divider plate: The divider plate can be either a fixed depth divider plate or a two-part adjustable depth divider plate held together in a loose fit condition by a factory fitted metal rivet style fastener that once set cannot be tightened or loosened, such that the adjustable divider plate system can be adjusted on site to the correct depth without the use of any tools.	Mild steel (DC01 to EN 10130 : 2006), pre-galvanized mild steel (DX51D to EN 10346 : 2015) or stainless steel (304 or higher grades)	The thickness of the material can range from 1 to 4 mm depending on the depth of the slab. Fixed depth divider plates are available in any size to suit a joint size of 90 mm upwards. Typically, the adjustable divider plate system is made in 30 or 50 mm increments such as 100 to 150 mm, 150 to 200 mm, 200 to 250 mm, 250 to 300 mm etc.	A3.1 and A3.2
Dowels ⁽¹⁾ : The dowels are Metal Inert Gas (MIG) factory welded to the divider plate or can be factory fitted in place with mechanical fasteners and bracketry.	Mild steel (S275 or S355 to EN 10029 : 2010), hot dip galvanized mild steel (85 µm minimum to EN ISO 1461 : 2009), or stainless steel (304 or higher grades)	6 x 100 x 100 mm, 6 x 150 x 150 mm, 8 x 150 x 150 mm or 12 x 150 x 150 mm thick square plate	A3.1 and A3.2

(1) Dowels pass through the divider plate on regular intervals. The dowels are positioned through the divider plate such that the 100 x 100 mm size is 40 mm on the fixed side of the joint leaving 60 mm on the free side of the joint allowing for a maximum of 20 mm joint opening, and the 150 x 150 mm size is 60 mm on the fixed side of the joint leaving 90 mm on the free side of the joint allowing for a maximum of 30 mm joint opening.

Figure A3.1 Shieldjoint with adjustable depth divider plate (view on fixed side of the joint)

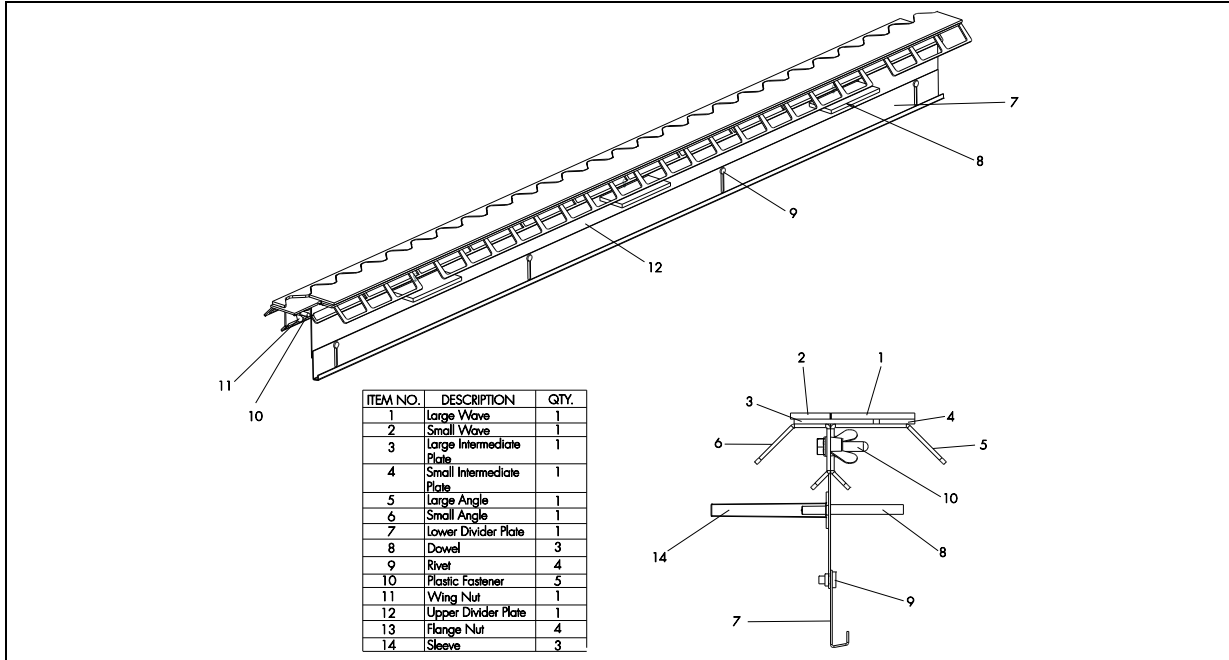
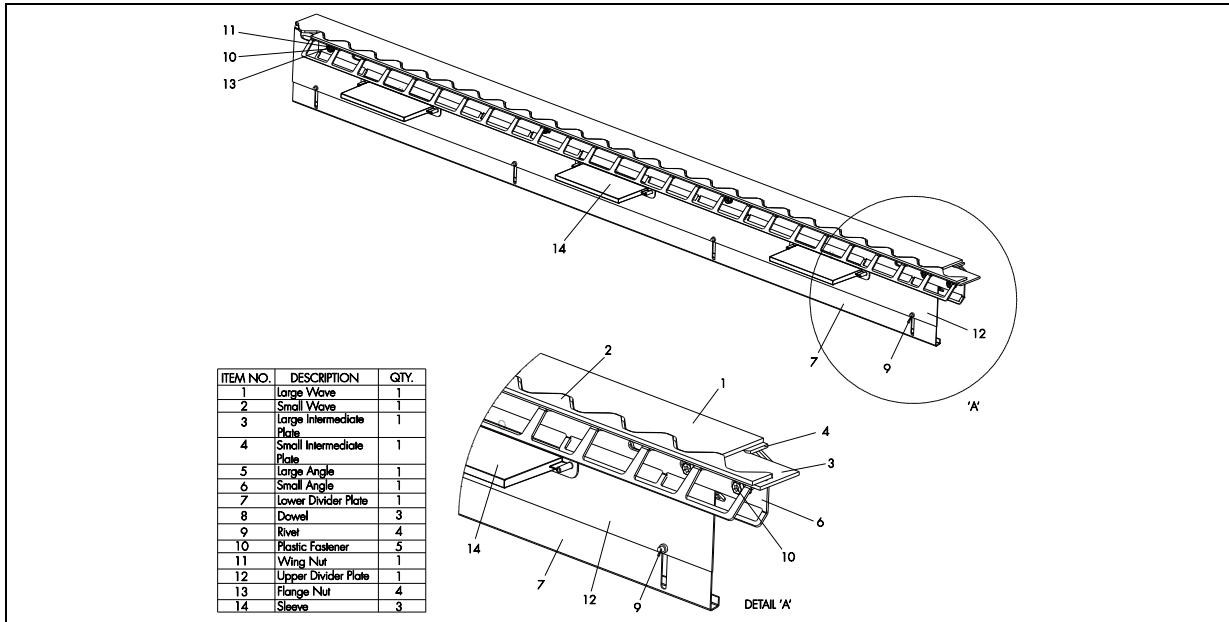
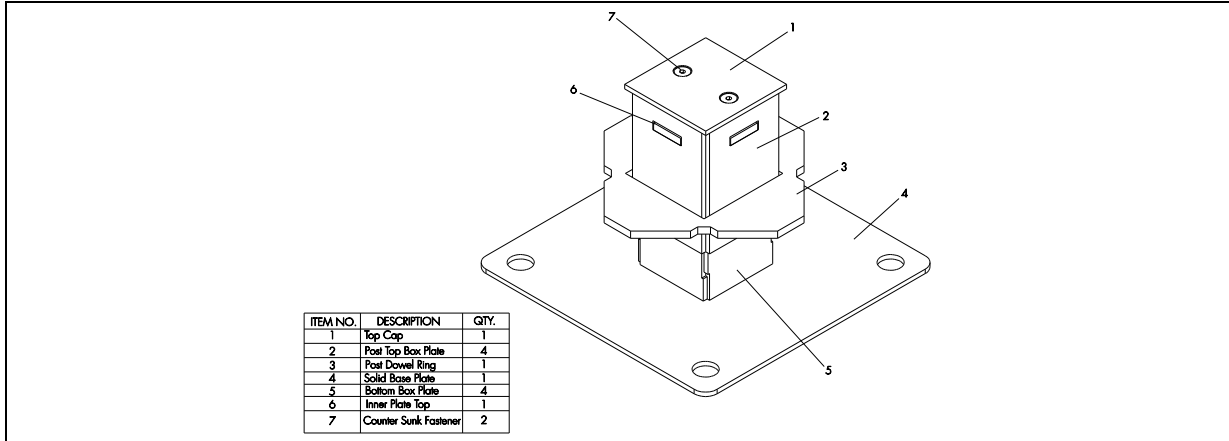

Figure A3.2 Shieldjoint with adjustable depth divider plate (view on free side of the joint)



Where Shieldjoints meet at an intersection between slab panels, an intersection post (see Figure A3.3) that can provide four way, three way or corner configurations must be used. Intersection posts are made under factory control and on-site construction of intersections must not be undertaken.

Figure A3.3 Shieldjoint Intersection Post



A4 Steeldeckjoint

Steeldeckjoint (see Figure A4.1) comprises a top section (3 m long) and lower profile (length of profile from 0.1 to 3 m) both manufactured from 1 to 3 mm thick mild steel (DC01 to EN 10130 : 2006), pre-galvanized steel (DX51D to EN 10346 : 2015) or stainless steel (304 or better) or a combination of these materials. The lower profile has a mating shape that closely matches the steel deck profile, thus preventing concrete to flow in the trough of the steel deck. A folded upper angle is fitted above the lower section and the top edge of the angle is the finished floor level. Both parts are mechanically fastened to the steel decking at regular intervals. Once one side of the joint former has concrete cast against it, round dowel bars or square dowel bars are fitted through the upper angle in to the wet concrete. Once the second side of the joint former has concrete cast against it, the dowels provide load transfer across the tied joint.

Figure A4.1 Steeldeckjoint

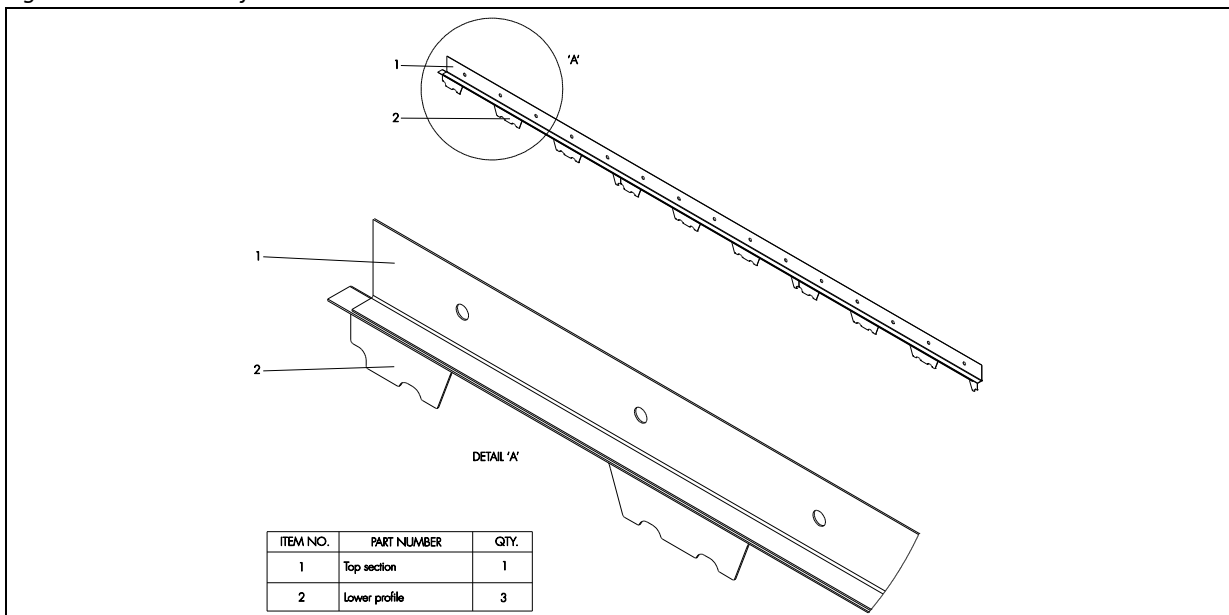

ANNEX B - DOWEL LOAD TRANSFER CAPACITY

This Annex applies to all joint former systems described in the main body of the European Technical Assessment.

This proposed methodology for calculating the load transfer capacity of dowels is adopted from TR34, Fourth edition (2016). The dowels are classified to bar dowels and plate dowels and the calculation method is presented for each separately.

B1. Conventional bar dowels

Dowels in accordance with EN 13877-3 : 2004 are short lengths of smooth steel of either round, square or rectangular section used at joints to enable loads to be transferred from one side of the joint to the other with no significant differential deflection.

The shear capacity is given by:

$$P_{sh\ dowel} = 0.6 f_{yd} A_v \quad \text{Equation 1}$$

Where: $f_{yd} = f_{yk}/\gamma_c$ = design yield strength of dowel

A_v = Shear Area of taken as 0.9 x area of the dowel section

f_{yk} = yield strength of dowel

γ_s = partial safety factor for steel, taken as 1.15.

The table below shows the calculated values for $P_{sh\ dowel}$ using Equation 1 for a 10 mm diameter round dowel bar in grade S275 mild steel;

Bar dowel type	Diameter (mm)	f_{yk} (N/mm ²)	γ_s	A_v (mm ²)	$P_{sh\ dowel}$ (N)
Round	10	275	1.15	70.65	10136

The table below shows the calculated values for $P_{sh\ dowel}$ using Equation 1 for a 25 x 25 mm cross section square dowel bar in grade S275 mild steel;

Bar dowel type	Width (mm)	Thickness (mm)	f_{yk} (N/mm ²)	γ_s	A_v (mm ²)	$P_{sh\ dowel}$ (N)
Square	25	25	275	1.15	562.50	80706

The bearing/bending capacity per dowel, P_{bear} , is given by:

$$P_{max\ dowel} = d_a^2 (f_{cd} f_{yd})^{0.5} [(1 + \alpha^2)^{0.5} - \alpha] \quad \text{Equation 2}$$

Where: d_a = diameter of round dowel or width of a square bar

$f_{cd} = f_{ck}/\gamma_c$ = concrete design compressive cylinder strength

$f_{yd} = f_{yk}/\gamma_s$ = characteristic strength of steel dowel

$\alpha = 3e[(f_{cd}/f_{yd})^{0.5}]/d_a$

e = half of joint opening width

Due to the fact that the concrete strength and joint opening are unknown variables, simplification of Equation 2 or typical examples for a given dowel cannot be provided.

B2. Plate dowels

Discrete plate dowels are commonly used as alternatives to traditional bar dowels. These are not to be confused with continuous plate dowels which have been found to perform poorly in service and are not recommended.

The shear capacity is given by:

$$P_{sh\ plate} = A * 0.9 * 0.6 p_y \quad \text{Equation 1}$$

Where: A = cross-sectional area of plate

p_y = plate steel design yield strength

The table below shows the calculated values for $p_{sh\ plate}$ using Equation 1 for various plate dowels in grade S275 and S355 mild steel;

Plate dimensions (mm)	A (mm ²)	p_y (N/mm ²)	$p_{sh\ plate}$ (N)
6 x 100 x 100	600	275	89100
6 x 150 x 150	900	275	133650
8 x 150 x 150	1200	355	230040
12 x 150 x 150	1800	355	345060

The bearing/bending capacity per plate dowel is given by:

$$P_{max\ plate} = 0.5[(b_1^2 + c_1)^{0.5} - b_1] \quad \text{Equation 2}$$

Where: $b_1 = 2ek_3f_{cd}P_b$

$$c_1 = 2k_3f_{cd}P_b^2t_p^2f_{yd}$$

e = half of joint opening width

$k_3 = 3$, a constant determined empirically

$f_{cd} = f_{ck}/\gamma_c$ = concrete design compressive cylinder strength

P_b = Plate width

t_p = Plate thickness

$f_{yd} = f_{yk}/\gamma_s$ = characteristic strength of steel plate

Due to the fact that the concrete strength and joint opening are unknown variables simplification of Equation 2 or typical examples for a given dowel cannot be provided.

ANNEX C – THERMAL PERFORMANCE AND CONDENSATION RISK

C1. Thermal Performance

The lambda value for materials used in the manufacture the joint formers is $45 \text{ Wm}^{-1}\text{K}^{-1}$ for mild steel and $14 \text{ Wm}^{-1}\text{K}^{-1}$ for stainless steel. For determining performance, U-values and ψ -values will depend on the detail construction of the whole slab system comprising voids, insulation, concrete slab, joint formers, screed and walls.

C2. Condensation Risk

The risk of surface condensation for elements and junctions incorporating the system shall be determined by comparison of temperature factors, f_{Rsi} , (established in accordance with EN ISO 10211 : 2017) with the maximum temperature factor, $f_{Rsi,max}$ (established in accordance with EN ISO 13788 : 2012). Elements and/or junctions are acceptable when $f_{Rsi} > f_{Rsi,max}$. To determine performance, condensation risk is dependent on detail construction of the whole slab system comprising voids, insulation, concrete slab, joint formers, screed and walls.